



**ADDENDUM No. 2**  
**Request for Competitive Sealed Proposals (CSP)**  
**21CSP034 Roofing Repairs at Martin Middle School**

October 26th, 2020

Received by bidder:

Date: \_\_\_\_\_

Name: \_\_\_\_\_

Signature: \_\_\_\_\_

**Item 1: Revisions to Specifications and Drawings**

**Item 1:**

Revisions to Specifications and Drawings can be found at  
<https://planroom.millerids.com/> under 21CSP034.

**ADDENDUM NO. 2**

Roofing Repairs at Martin Middle School  
Austin Independent School District  
Solicitation No.: 20CSP106

**Addendum Date:** October 22, 2020

**Bid Due Date:** November 3, 2020 @ 2:00 P.M.



**Notice to Bidder**

- A. This Addendum shall be considered part of the Contract Documents for the above-mentioned project as though it had been issued at the same time and incorporated therewith. Where provisions of the following supplementary data differ from those of the original Contract Documents, this Addendum will govern and take precedence.
- B. Bidders are hereby notified that they shall make any necessary adjustment in their estimates on account of this Addendum. It will be construed that each Bidder's proposal is submitted with full knowledge of all modifications and supplemental data specified herein.
- C. Acknowledge receipt of this Addendum by inserting its number and date on the Proposal Form.

**Changes to Bid Documents**

- ITEM 1:** Refer to Specifications: Section 07 0152 – Preparation for Roof Restoration. Delete this Section in its entirety and replace with the section of the same name, attached to this addendum.
- ITEM 2:** Refer to Specifications: Section 07 5565 – Thermoplastic Roofing Overlay System. Delete this Section in its entirety and replace with the section of the same name, attached to this addendum.
- ITEM 3:** Refer to Specifications: Section 07 5800 – Elastomeric Roof Coating. Delete this Section in its entirety and replace with the section of the same name, attached to this addendum.
- ITEM 4:** Refer to Specifications: Section 07 7200 – Roof Accessories. Delete this Section in its entirety and replace with the section of the same name, attached to this addendum.
- ITEM 5:** Refer to Drawings: Sheets R0, R1, R2, R3, R4, R5. Delete these sheets in their entirety and replace with the drawing sheets of the same name, attached to this addendum.

**END OF ADDENDUM NO. 2**

SECTION 07 0152

PREPARATION FOR ROOF RESTORATION

PART 1 - GENERAL

1.1 RELATED DOCUMENTS

- A. Drawings and general provisions of the Contract, including General and Supplementary Conditions and other Division 01 through Division 26 Specification Sections, apply to this Section.

1.2 SUMMARY

- A. Section Includes:
  - 1. Infrared roof moisture survey.
  - 2. Removal of flashings and counterflashings.
  - 3. Re-cover preparation of roof areas indicated on Drawings.
  - 4. Insulation replacement.
  - 5. Cementitious deck repair.
- B. Related Sections
  - 1. Section 01 2200 - Proposal Items
  - 2. Section 01 7830 - Roofing Installer's Warranty
  - 3. Section 07 5565 - Thermoplastic Roof Overlay System
  - 4. Section 07 6200 - Flashing and Sheet Metal

1.3 MATERIALS OWNERSHIP

- A. Except for items or materials indicated to be reused, reinstalled, or otherwise indicated to remain Owner's property, demolished materials shall become Contractor's property and shall be removed from Project site

1.4 SUBMITTALS

- A. Comply with provisions of Division 01.
- B. Mark each product data cut-sheet by circling or highlighting and affix the corresponding Article and Paragraph designations from this Specification Section. Product data not so marked will be returned without review, for re-submittal complying with the above requirements.
- C. Submit current catalogs/brochures describing products for review, coordination and final approval for use on this Project.
- D. Submit Photographs or Videotape: Show existing conditions of adjoining construction and site improvements, including exterior and interior finish surfaces that might be misconstrued as having been damaged by reroofing operations. Submit before Work begins.
- E. Submit a demolition plan indicating at a minimum the following:
  - 1. Schedule of demolition detailed to correspond to re-roofing operations.

2. Requirements of staging including methods proposed for transport of materials from the roof to the ground.
3. Submit containment fence layout, materials and support structure for rooftop and ground locations.

F. Infrared Roof Moisture Survey:

1. Contractor shall provide the services of an independent non-destructive testing (NDT) company to perform an infrared roof moisture survey in conformance with ASTM C1153-10(2015) – “Standard Practice for Location of Wet Insulation in Roofing Systems Using Infrared Imaging”.
2. Infrared roof moisture survey shall be conducted at night at a date / time coordinated and agreeable with the Architect and Owner.
3. Submit a bound report in pdf format from the NDT company signed by the Lead Technician or Licensed Professional Engineer including, but not limited to, the following:
  - a. Date(s), time(s) and environmental conditions during testing.
  - b. Technician(s) name(s), experience, qualifications and certifications. (Note: Lead technician must have a current ASNT Level I certification in Infrared Thermography.)
  - c. Equipment used and recalibration certificate. (Note: Infrared thermography equipment must have been recalibrated within the previous twelve (12) months.)
  - d. Written description and summary of findings.
  - e. Quality scaled drawing depicting the entrained moisture areas on the roof.
4. Roof restoration work shall not commence until after an infrared roof moisture survey report has been received and accepted by the Architect.

1.5 PROJECT CONDITIONS

- A. Owner will occupy portions of building immediately below reroofing area. Conduct reroofing so Owner's operations will not be disrupted. Provide Owner with not less than 72 hours' notice of activities that may affect Owner's operations.
  1. Coordinate work activities daily with Owner so Owner can place protective dust or water leakage covers over sensitive equipment or furnishings, shut down HVAC and fire-alarm or -detection equipment if needed, and evacuate occupants from below the work area.
  2. Before working over structurally impaired areas of deck, notify Owner to evacuate occupants from below the affected area. Verify that occupants below the work area have been evacuated before proceeding with work over the impaired deck area.
- B. On days when the buildings are occupied the Contractor may observe Work hours between 7:00 a.m. and 6:00 p.m., Monday through Friday. Work may not occur after 6:00 p.m. unless permission is granted in writing by the Owner and Architect prior to the occurrence, or in the case - subject to the Owner and Architect's approval - where unanticipated conditions cause the time to be extended. Overnight work is not acceptable.
- C. Protect building to be reroofed, adjacent buildings, walkways, site improvements, exterior plantings, and landscaping from damage or soiling from reroofing operations.
- D. Maintain access to existing walkways, corridors, and other adjacent occupied or used facilities.

- E. Weather Limitations: Proceed with reroofing preparation only when existing and forecasted weather conditions permit Work to proceed without water entering existing roofing system or building.
- F. Hazardous Materials: It is not expected that hazardous materials such as asbestos-containing materials will be encountered in the Work.
  - 1. If materials suspected of containing hazardous materials are encountered, do not disturb; immediately notify Architect and Owner.
- G. The allowable weight distribution for roof areas is 20 pounds per square foot.
  - 1. Remove demolished roofing products from the roof to the ground immediately with no stacking of materials permitted.
  - 2. Transfer materials direct from the ground into ground-based trash containers and remove from the project upon completion of demolition.
  - 3. Take precautions to prevent damage to surfaces by ground-based disposal units.
- H. In the event of the discovery of unanticipated substrates, or damaged or deteriorated structural components, immediately advise the Architect and await instructions prior to proceeding, unless otherwise directed. Repair and/or replace damaged or deteriorated decking in strict compliance with this Section, or as otherwise directed by the Architect.
- I. Coordinate with Owner to shut down air-intake equipment in the vicinity of the Work. Cover air-intake louvers before proceeding with reroofing work that could affect indoor air quality or activate smoke detectors in the ductwork.

## PART 2 - PRODUCTS

### 2.1 ROOF INSULATION

- A. General: Preformed roof insulation boards manufactured or approved by roofing manufacturer, selected from manufacturer's standard sizes suitable for application, of thicknesses indicated.
- B. Rigid Insulation Board: Rigid flat and tapered perlite board meeting ASTM C-728 and F.S. HH-I-529b. Thickness of new insulation shall match existing.
- C. Adhesive: As recommended by roof membrane manufacturer; quick-setting "OlyBond 500" adhesive, or an approved equal. (Note: Duotack 365 is not acceptable.)
- D. Accessories: Furnish roof insulation accessories recommended by insulation manufacturer for intended use and compatibility with membrane roofing.

### 2.2 BASE SHEET MATERIALS

- A. Fiberglass Base Sheet: Asphalt-impregnated fiberglass mat, produced by the roofing membrane manufacturer, and meeting requirements of ASTM D-4601, Type II.
- B. Fasteners: Factory-coated steel fasteners and metal plates complying with corrosion-resistance provisions in FMG Approvals 4470; designed for fastening roofing membrane components to substrate; tested by manufacturer for required pullout strength, and acceptable to roofing system manufacturer.
  - 1. Mechanical Fasteners for Base Sheet:

- a. Lightweight Concrete Deck: Coated nail and plate: ES-90 by ES Products or approved equal.
- b. Secondary Disks for Fasteners: Sized to meet requirements to resist wind up-lift pressures prescribed by ASCE 7 and FM Class 90.
- c. Plastic plates are not acceptable.

### 2.3 CEMENTITIOUS DECKING REPAIR OR REPLACEMENT

- A. Cementitious Deck Patching Material: Siplast "Zonopatch," or a prior-approved equal.

## PART 3 - EXECUTION

### 3.1 PREPARATION/DEMOLITION - RESTORATION

- A. Remove loose dust, dirt, granules, and debris from roof surface per manufacturer's recommendations.
- B. At metal-clad membrane flashings and targets scheduled to remain heat or otherwise loosen metal cladding only. Remove metal cladding from membrane base flashings taking care not to damage underlying membrane.
- C. At granulated membrane flashings and targets scheduled to remain heat and embed existing granules.
- D. Remove only metal flashings designated for removal.
- E. Remove counter flashing without damage to receivers or deformation of sheet metal flashing designated to remain.
- F. Provide temporary support and protection of piping and conduits.
- G. Bring accessories which the Contractor may deem no longer necessary to the attention of the Architect.
  1. Any removed accessories are to be considered the property of the Owner, who reserves the right to retain possession.
  2. Equipment and/or any materials removed, not used, and not claimed by the Owner, shall be removed and properly disposed of offsite.

### 3.2 INSULATION REPLACEMENT

- A. Insulation & Base Sheet Replacement (IBSR) (**Unit Price No. 4**): The following procedures shall be followed:
  1. Wet insulation as identified by infrared roof moisture survey will be removed in its entirety to the surface of the existing deck.
  2. New mechanically fastened base sheet shall be installed.
  3. New adhered insulation to match existing thicknesses shall be installed
  4. New 2-ply modified patch set in cold process adhesive shall be installed.

### 3.3 REPAIR OF DAMAGED OR DETERIORATED CEMENTITIOUS DECKING

- A. Notify the Architect immediately upon discovery of any deteriorated deck conditions. Do not proceed without direction.

- B. There is the possibility that water leakage may have caused failure in the cementitious decking in isolated areas. Care shall be taken during demolition to ensure the safety of the workers. There is no current knowledge of any failed deck components.
- C. Closely inspect the deck surfaces immediately upon completion of roofing demolition. Deck repairs will be added to the Contract Amount and paid for by duly authorized Change Order, utilizing the unit prices in the Contract.
- D. Cementitious Deck Repair No. 1 (CDR-1) (**Unit Price No. 5**): Deck deterioration where the metal form deck or form board is intact in areas equal to or less than 48 inches x 48 inches, or 16 square feet maximum, shall be repaired by the following procedure.
  - 1. Remove damage to existing form deck. Sweep existing metal or form board clean.
  - 2. Install specified cementitious repair product mixed and applied in accordance with the manufacturer's instructions.
- E. Cementitious Deck Repair No. 2 (CDR-2) (**Unit Price No. 6**): Deck deterioration in areas greater than the area cited in Cementitious Deck Repair No. 1 and over damaged metal form deck or form board, shall be repaired by the following procedure:
  - 1. Remove existing damaged cementitious fill and metal or form board deck. Remove deck to the nearest structural supports in every direction. Do not drop materials into the building.
  - 2. Neatly saw-cut the end and edges of existing cementitious fill to a point where acceptable material is encountered.
  - 3. Completely remove loose material from the metal or form board deck surfaces.
  - 4. Install new metal deck to match existing supporting it on the nearest bulb tees or other structural supports.
  - 5. Complete repair as shown on the drawings.
- F. Cementitious Deck Repair No. 3 (CDR-3) - Hole Repair, (**Unit Price No. 7**):
  - 1. Hole repairs do not require prior notification to the Architect and may occur while classes are in session.
  - 2. Holes through deck measuring less than 12-inches in diameter or sides shall be repaired by attaching one layer of 10-gauge galvanized metal with insulation screws spaced at 6-inches on centers, maximum.
  - 3. The new repair metal shall lap over the existing decking by a minimum of 6 inches on all sides of the hole.

### 3.4 CLEANING

- A. Clean walks, drives and other surfaces daily. Promptly pick up and dispose of debris outside the containment fencing.

### 3.5 RECORDS

- A. Accurately record structural element repairs on the Project Record Documents ("as-built" drawings).

END OF SECTION 07 0152

## SECTION 07 5565

## THERMOPLASTIC ROOFING OVERLAY SYSTEM

PART 1 – GENERAL

## 1.1 RELATED DOCUMENTS

- A. Drawings and general provisions of the Contract, including General and Supplementary Conditions and other Division 01 through Division 26 Specification Sections, apply to this Section.

## 1.2 SUMMARY

- A. Section Includes:
  - 1. Thermoplastic membrane overlay of existing roofing system.
  - 2. Roof cover boards and adhesive pull tests.
  - 3. Membrane and cover board adhesives
  - 4. Base flashings.
- B. Related Sections
  - 1. Section 01 7830 - Roofing Installer's Warranty
  - 2. Section 06 1050 - Roof Carpentry
  - 3. Section 07 6200 - Flashing and Sheet Metal
  - 4. Section 07 7200 - Roof Accessories

## 1.3 DEFINITIONS

- A. Roofing Terminology: See ASTM D 1079 and glossary of NRCA's "The NRCA Roofing and Waterproofing Manual" for definition of terms related to roofing work in this Section.

## 1.4 PERFORMANCE REQUIREMENTS

- A. General Requirements: Provide an installed thermoplastic single ply roofing overlay system, flashings and related work that are watertight and will not permit the passage of liquid water, that will withstand wind loads, thermally induced movement, and exposure to weather without failure.
- B. Material Compatibility: Provide roofing materials that are compatible with one another under conditions of service and application required, as demonstrated by roofing system manufacturer based on testing and field experience.
- C. Underwriters Laboratories Inc. (UL):
  - 1. Exterior Fire Exposure Classification: Class A, ASTM E 108, for application and slopes shown.
- D. FM Listing, General Performance, Wind Uplift: Provide sheet membrane, base flashings, and component materials that comply with requirements in FM Approvals 4450 and FM Approvals 4470 as part of a roofing system and as listed in the FM Approvals' "RoofNav"



for a Class 1 or noncombustible construction as applicable. Identify materials with FM markings. Roofing System shall comply with the following:

1. FM D/S1-29 – 2006 Adhered Single Ply Roof System.
2. Fire Resistance: Class 1A.
3. Hail Resistance Rating: SH

#### 1.5 SUBMITTALS

- A. Comply with provisions of Division 01.
- B. Mark each product data cut-sheet by circling or highlighting and affix the corresponding Article and Paragraph numbers from this Specification Section. Product data not so marked will be returned without review, for re-submittal complying with the above requirements.
- C. Product Data: For each type of product indicated. Include installation sequence, special instructions and Material Safety Data Sheets (MSDS) for materials.
- D. Manufacturer's Certification: Provide current letter(s) on membrane manufacturer's letterhead, signed by an authorized employee or corporate officer attesting to the following:
  1. Products: Certify that roofing system complies with requirements specified in "Performance Requirements" Article.
  2. Roofing system components are physically and chemically compatible for installation as designed.
  3. Proposed materials, including those by other manufacturer, are acceptable to membrane manufacturer for use in system.
  4. Proposed system meets criteria for issuance of required manufacturer's warranty.
  5. Specifically identify and define any deviations.
- E. Installer Certificates: Signed by roofing system manufacturer certifying that Installer is approved, authorized, or licensed by manufacturer to install roofing system.
- F. Manufacturer's Field Reports: Summarize findings of each inspection. Indicate any discrepancies from recommended installation methods, corrective action recommended to installer, and any non-compliant or unsatisfactory conditions.
- G. Pull Tests Report: Submit pull tests report for adhesive pull tests on cover board installation including:
  1. Project name and location.
  2. Test date(s).
  3. Climatic conditions.
  4. Test Apparatus model and calibration date.
  5. Name of testing company and technician.
  6. Tested materials.
  7. Test results including failure mode, if any.
  8. Scalable roof plan indicating test locations with photographs of each test zone and apparatus at the required testing limit.

- H. Project Record Documents: Accurately record exact location of roof membrane penetrations and authorized changes to Contract Documents.
1. Draw roof area to scale of 1/4-inch per foot or 1/8-inch per foot. Identify school, address and location on campus referenced to Architect's original roof areas.
  2. Show the entirety of the roof area being repaired or modified along with current penetrations and roof features.
  3. Include north arrow and name and area of building.
  4. Include Contractor's name, address, phone and fax numbers.
  5. Accurately show location of Work and neatly explain action taken. Include list of materials used and brand name and manufacturer of each. This information may be attached to the roof plan on additional pages and follow the format shown in 3.4 below

#### 1.6 QUALITY ASSURANCE

- A. Manufacturer: Company specializing in manufacturing products and systems specified in this Section with minimum five years documented experience.
- B. Installer: A qualified firm that has been continuously approved, authorized, or licensed by roofing system manufacturer to install manufacturer's product and specified roof system for a minimum period of 3 years prior to bid date..
- C. Perform Work in adherence to manufacturer's requirements to prevent voiding existing warranties.
- D. Source Limitations: Obtain components for roofing system from or approved by roofing system manufacturer.
- E. Perform Work in accordance with NRCA Manual of Roof Maintenance and Roof Repair, NRCA Roofing and Waterproofing Manual, and manufacturer's instructions.
- F. Workers: All roofers and laborers to be direct employees of Primary Contractor.
1. Project Manager and Superintendent: Minimum five years roofing experience and employed by Contractor for a minimum one year prior to Bid Date.
  2. Non-working Supervisor: Able to communicate effectively with School staff and Applicator's workers and employed by Contractor for a minimum one year prior to Bid Date.
  3. Tradesmen: Minimum 50-percent of installation crew to have been employed by Contractor for a minimum six months prior to Bid Date.
- G. Assign a qualified, full time, non-working supervisor to be on Project site always during installation of Work.
- H. Do not allow materials which have not been approved through the submittal process to be brought onto the project site. Any materials brought onto the site which have not been approved through the submittal process will be rejected and shall be removed immediately. Remove - without appeal or exception - any materials incorporated into the Work that have not been approved through the specified submittal process.
- I. Cover Board Adhesive Pull Test: Contractor shall provide adhesive pull testing of the affixed cover board prior to installation of thermoplastic overlay membrane.
1. Pull tests shall be performed by an independent third party qualified to perform the

- tests in general conformance with ASTM D3359.
2. Pull test apparatus shall be pre-manufactured and consist of a metal base and uplift frame, 2 ft. x 2 ft. metal uplift plate, and calibrated gauge pull tester (2000 lb or 500 psf max., analog or digital).
  3. Uplift plate adhesive shall be allowed to bond properly for a period of 24 hours prior to testing.
  4. Quantity, Location and Test Limits:
    - a. Two tests shall be performed.
    - b. One test shall be located in the field of the roof and one test shall be located in an 8 ft. perimeter zone as directed by the Owner's representative.
    - c. Roof field zone test limit shall be 400 lb or 100 psf. Roof perimeter zone test shall be 560 lb. or 140 psf.
  5. Uplift force shall be applied in increments of 80 lb. or 20 psf and held for a period of 20 minutes before applying additional force. The test limit shall be held for 30 minutes.
  6. Adhesive failure shall require two additional pull tests to be performed until there are no failures. Otherwise, corrective action may be required.
  7. Contractor shall replace damaged cover board at no additional cost to the Owner.
- J. The manufacturer's representative shall make a minimum of two (2) site visits to the project per month at critical stages of the roof installation, and forward to the Architect written reports of the observations and instructions given to the Contractor during these visits. Coordinate the visits to take place at the time of the Architect's visits, with one occurring at the monthly pay application meeting. Include at the minimum the following information in manufacturer's representative's reports:
1. Prepare reports typewritten on the manufacturer's letterhead stationery and submit to the Architect within seven (7) days of the site visit.
  2. Document Work in progress and list deficiencies, corrective actions and recommendations.
  3. Failure of the manufacturer's representative to provide the required reports in a timely manner is cause for rejection of the Contractor's pay application.

#### 1.7 PRE-INSTALLATION CONFERENCE

- A. Convene a pre-installation conference two weeks prior to commencing Work. Those in attendance shall be the Contractor's Project Manager and Superintendent, Manufacturer's Representative, Owner and Owner's Director of Facilities Representative(s), Architect and his designated representative(s).
1. Review methods and procedures related to roofing installation, including manufacturer's written instructions.
  2. Review and finalize construction schedule, and verify availability of materials, Installer's personnel, equipment, and facilities needed to make progress and avoid delays.
  3. Examine deck substrate conditions and finishes for compliance with requirements, including flatness and fastening.
  4. Review structural loading limitations of roof deck during and after roofing.
  5. Review base flashings, special roofing details, roof drainage, roof penetrations, equipment curbs, and condition of other construction that affects roofing system.
  6. Review governing regulations and requirements for insurance and certificates if applicable.

7. Review temporary protection requirements for roofing system during and after installation.
8. Review roof observation and repair procedures after roofing installation.

- B. Produce accurate and comprehensive written minutes of the meeting and distribute copies to each party.

#### 1.8 DELIVERY, STORAGE, AND HANDLING

- A. Deliver roofing materials to Project site in original containers with seals unbroken and labeled with manufacturer's name, product brand name and type, date of manufacture, approval or listing agency markings, and directions for storing and mixing with other components.
  1. Inspect for damage. Replace damaged or deteriorated materials.
  2. Store products in weather protected environment, clear of ground and moisture.
  3. Stand and store roll materials on ends.
  4. Coordinate shipment receipt as necessary to cause Owner least amount of interference in Owner's operations. Owner will not take responsibility for product deliveries.
- B. Store liquid materials in their original undamaged containers in a clean, dry, protected location and within the temperature range required by roofing system manufacturer. Protect stored liquid material from direct sunlight.
  1. Discard and legally dispose of liquid material that cannot be applied within its stated shelf life.
- C. Protect roof insulation materials from physical damage and from deterioration by sunlight, moisture, soiling and other sources.
  1. Store cover board, adhesive and other materials subject to water damage in fully enclosed, watertight storage trailers.
  2. Organize cover board bundles to prevent condensation buildup. Ventilate shipping wrappers upon receipt.
  3. Promptly mark, remove from the site and discard any materials contaminated by moisture.
- D. Handle and store roofing materials and place equipment in a manner to avoid permanent deflection of deck.
  1. Do not store materials on roof overnight unless approved by the Architect.
  2. Maximum Allowable Loading on Roof: 20 pounds per square foot.

#### 1.9 PROJECT CONDITIONS

- A. Weather Limitations: Proceed with installation only when existing and forecasted weather conditions permit roofing system to be installed per manufacturer's written instructions and warranty requirements.
  1. Do not apply roofing membrane during inclement weather.
  2. Do not apply roofing membrane to damp or frozen deck surface.
  3. Observe wind chill and other cold weather conditions for proper bituminous application.
- B. Do not apply any portion of the roofing system or its accessories, or start operations in the event precipitation is threatening, unless proper precautions are taken for same. The

Contractor shall have the final decision as to whether to chance roofing operations in the event wet conditions threaten and shall consider wind speed as a determining factor as to whether roofing operations can be safely accomplished under such conditions. The Contractor shall suspend Work if, in his/her opinion, wind speed will impede the proper installation of the roofing Work, or cause a danger to his/her personnel, or to the Owner's property.

- C. Do not remove any part of the roof and leave overnight without the application of a fully watertight temporary or permanent repair.
- D. Prevent water migration into building by installation of roofing membrane and flashings. At no time leave the building in an open state that would allow water penetration.

#### 1.10 ENVIRONMENTAL REQUIREMENTS

- A. Do not apply roofing during inclement weather. Temperatures must be a minimum of 40° F and rising.
- B. Do not apply roofing material to damp or frozen deck or substrate.
- C. Do not undertake roofing operations when the wind is determined to be detrimental to safe installation practices.

#### 1.11 REGULATORY REQUIREMENTS

- A. Fire Hazard Classification: UL Class A.
- B. Roof Assembly Classification: FM Class 1-90 construction, in accordance with FM Construction Bulletin 1-28.

#### 1.12 SEQUENCING AND SCHEDULING

- A. Coordinate Work under provisions of the appropriate Division 01 Section regarding administrative requirements.”
- B. Coordinate with demolition Work and with Work of other trades to ensure sufficient materials and manpower are available to complete and make watertight roofing Work each day.
- C. Limit tear-off of existing roof system to amount that can be completely covered with new roof system and made watertight by end of day.
- D. Coordinate installation of associated metal flashings, and roof-related items as Work of this Section proceeds. Strip-in flanged metal components to roof membrane on same day they are installed.
- E. Schedule Work to avoid storage on and traffic over finished Work.
- F. Mount and always maintain a minimum of two (2) fully charged and workable 3A60BC class fire extinguishers at the roof level Work is underway. Position fire extinguishers no farther than 25 feet from torching operations. Train workers in proper fire extinguisher use.

## 1.13 WARRANTY

- A. Provide a two-year written warranty covering defects in the roofing materials and labor, on the form in Section 01 7830.
- B. Provide the roofing materials manufacturer's 20-year no-dollar-limit warranty covering full replacement of defective roofing materials and labor.
- C. Commence warranties on the Date of Substantial Completion for the overall project.

PART 2 - PRODUCTS

## 2.1 THERMOPLASTIC MEMBRANE MANUFACTURERS

- A. Carlisle
- B. Johns Manville
- C. Sika Sarnafil
- D. Siplast
- E. Soprema

## 2.2 SHEET MATERIALS

- A. Single Ply Membrane at fully adhered Thermoplastic Overlay Roof System:
  - 1. Carlisle Sure-Flex 80 mil PVC KEE HP FleeceBACK
  - 2. Johns Manville: JM PVC FB: 80 mil; fleeceback
  - 3. Sika: Sarnafil G410: 80 mil; feltback
  - 4. Siplast: ParaSolo PVC KEE: 80 mil; fleeceback
  - 5. Soprema: Sentinel P200 HFB: 80 mil; fleeceback
- B. Single Ply Membrane Properties: Polyester fabric reinforced, heat-weldable sheets; fabricated from thermoplastic (PVC/KEE) with permanent, non-migrating plasticizers; minimum thickness listed in Article 2.2.A; UL Class A.
  - 1. Membrane to be resistant to puncture, tearing, elongation, ultraviolet rays, micro-organisms, and caustic chemicals.
  - 2. Membrane exposed surface color to be white.

## 2.3 AUXILIARY MATERIALS

- A. General: Furnish auxiliary materials recommended by roofing system manufacturer for intended use and compatible with membrane roofing materials.
  - 1. Furnish liquid-type auxiliary materials that meet VOC limits of authorities having jurisdictions.
- B. Flashing and Flashing Accessories: 60 mil thickness, smooth backed; as recommended by the Thermoplastic sheet manufacturer's printed instructions for reinforced sheet flashing of same material type and color as sheet membrane.
- C. Overlay Membrane Bonding Adhesive: Spatter pattern; application rates are to be as recommended by thermoplastic sheet manufacturer's printed instructions.
  - 1. Carlisle Olybond 500

- |    |                 |                               |
|----|-----------------|-------------------------------|
| 2. | Johns Manville: | JM Two-part Urethane Adhesive |
| 3. | Sika:           | Sarnacol 2170                 |
| 4. | Siplast:        | Parafast IA                   |
| 5. | Soprema:        | Olybond 500                   |

- D. Flashing Membrane Bonding Adhesive: Manufacturer's adhesive used to attach the flashing membrane to the substrate, either horizontally or vertically. Application rates are to be as recommended by thermoplastic sheet manufacturer's printed instructions.
- E. Bonding Adhesive Application: Adhesive application shall be modified per manufacturer's recommendations for time of year and prevailing daytime temperatures.
- F. Metal Termination Bars: Manufacturer's standard aluminum bars, approximately 1-inch (25-mm) wide, roll formed and pre-punched every 6 inches on center.
- G. Sealants: Membrane manufacturer's approved sealant shall be used to seal penetrations through the membrane system and at miscellaneous sealant applications that are exposed to roof systems components.
- H. Membrane Securement Bar: An approved, heavy-duty 12 gauge, galvanized or stainless, roll-formed steel bar used to attach membrane to the roof deck. The formed steel is pre-punched with holes every 1 inch on center to allow various fastener spacing options.
- I. Sealing Tape: A high performance sealant tape with superior surface tack that remains elastic and is designed to bond the PVC/KEE membrane and a variety of metals. Sealing tape strip is used to seal the metal roof edge of buildings reducing air infiltration into the roof assembly, behind the PVC/KEE membrane flashing at termination details, and to seal the overlaps of the air/vapor retarder membrane.
- J. Miscellaneous Accessories: Provide pourable sealants, performed cone and vent sheet flashings, performed inside and outside corner sheet flashings, T-joint covers, termination reglets, and other accessories as recommended by roofing system manufacturer for intended use.
- K. Other miscellaneous materials shall be of the "best grade" available and to be approved in writing by the roofing manufacturer, prior to use, for the specific application.
- L. PVC/KEE-Coated Metal: Manufacturer's standard membrane coated galvanized metal, 24 ga. minimum. See Section 07 6200 for fasteners and sealant.
- M. Expansion Joint Filler:
1. Flexible Vapor Retarder: Minimum 45 mil thick vinyl sheet or approved equal.
  2. Compressible Insulation: Fiberglass batt insulation or approved equal.
- 2.4 ROOF WALKWAY PADS
- A. Walkway Pads: A factory-formed, nonporous, heavy-duty, slip resisting, surface-textured protection pads, approximately 9/16 inch (14 mm) in thickness. Color of protection pads shall be Light Grey.
1. Acceptable Products:

- a. FiberTite CrossGrip (3' x 33' x 9/16") as manufactured by FiberTite, [www.fibertite.com](http://www.fibertite.com).
  - b. Crossgrip PVC (3' x 33' x 9/16") as manufactured by Plastex Matting Inc., [www.plastexmatting.com](http://www.plastexmatting.com).
  - c. Watco Roof Walkway Matting (3' x 33' x 9/16") as manufactured by Watco industrial Flooring, Inc., [www.watcofloors.com](http://www.watcofloors.com).
2. Pads shall be compatible with and acceptable to the roofing system manufacturer

## 2.5 ROOF COVER BOARD

- A. General: Preformed roof cover boards manufactured or approved by roofing manufacturer, selected from manufacturer's standard sizes suitable for application, of thicknesses indicated.
- B. Roof Cover Board:
  1. Over Field of Roof:
    - a. Type: High density polyisocyanurate foam core meeting requirements of ASTM C 1289, Type II, Class 4, Grade 1.
    - b. Thickness: 1/2-inch.
  2. Over Roof Curbs:
    - a. Type: High density polyisocyanurate foam core meeting requirements of ASTM C 1289, Type II, Class 4, Grade 1.
    - b. Thickness: 1/4-inch.
    - c. Miter edges of cover board strips at transitions.
  3. Board Size: Maximum 48-inches x 48-inches, fully adhered.

## 2.6 COVER BOARD ACCESSORIES

- A. General: Furnish roof cover board accessories recommended by cover board manufacturer for intended use and compatibility with membrane roofing.
- B. Cover Board Adhesive:
  1. Ribbon pattern; as recommended by roof membrane manufacturer; quick-setting "OlyBond 500" adhesive, or an approved equal.

## PART 3 - EXECUTION

### 3.1 EXAMINATION

- A. Examine and verify that receiving substrate surfaces of the structure have no defects or errors, which would result in poor or potentially defective application or cause latent defects in workmanship.
  1. Do not permit voids greater than 1/4-inch wide in the substrate. Substrates for roofing materials shall be dry and free of oil, dirt, grease, sharp edges, and debris. Inspect substrates, and correct defects before application of roofing system.
- B. Roofing contractor is to verify that roofing openings and penetrations are in place, set, and braced and that roof drains are properly clamped into position and are in a functional condition.



- C. Do not proceed with installation until unsatisfactory conditions have been corrected. Starting installation shall imply contractor's acceptance of surfaces and conditions

### 3.2 PREPARATION

- A. Clean substrate of dust, debris, and other substances detrimental to roofing installation per roofing system manufacturer's written instructions. Remove sharp projections.
- B. The roofing contractor will be entirely responsible for the complete removal of dirt, debris, moisture from the roof's substrate. The roof's substrate must be 100% completely dry before the installation of the specified roofing assembly.
- C. Fill gaps and voids between substrate components that are wider than 1/4 inch. Fill gaps with same materials as the substrate.
- D. Prevent materials from entering and clogging roof drains and conductors and from spilling or migrating onto surfaces of other construction. Remove roof-drain plugs when no work is taking place or when rain is forecast.
- E. Protect adjacent areas or surfaces from damage as a result of the Work of this section.
- F. Complete terminations and base flashings and provide temporary seals to prevent water from entering completed sections of the roofing system at the end of the workday or when rain is forecast. Remove and discard temporary seals before beginning work on adjoining roofing.

### 3.3 COVER BOARD INSTALLATION

- A. Cover board shall be laid in full sheets wherever possible, and carefully fitted and pushed against adjoining sheets or nailers, to form a tight joint.
  - 1. Butt cover boards tightly together.
  - 2. Walk-in boards to ensure solid adhesion.
  - 3. Stagger joints between adjacent boards.
  - 4. Fill open joints with tightly-fit pieces of matching cover board or roof insulation.
  - 5. Miter edges of cover boards at ridges and elsewhere to prevent open or irregular joints.
  - 6. Do not install more cover board than can be covered during each day's operation.
- B. Over Field of Roof: Fully adhere 1/2-inch thick cover board using low-rise foam adhesive ribbons at 6 inches on-center.
- C. Over Perimeter of Roof: For a depth of 8 feet from roof edges and wall abutments, fully adhere 1/2-inch thick cover board using low-rise foam adhesive ribbons at 4 inches on-center.
- D. Cover roof curbs and vertical surfaces where indicated with 1/4-inch cover board.
  - 1. Mechanically fasten to wood blocking with galvanized ring shank cap nails.
  - 2. Set in full embedment of low-rise foam adhesive at non-nailable substrates.
- E. Leave surfaces clean in preparation for roof membrane installation.

### 3.4 MEMBRANE APPLICATION

- A. Install PVC overlay membrane sheet per manufacturer's requirements in order to obtain manufacturer Twenty (20)-year Standard (NDL) System Warranty.
- B. Membrane welding equipment shall be provided by or approved by PVC Manufacturer. Mechanics intending to use the equipment shall have successfully completed a training course provided by the PVC Manufacturer Technical Service Representative prior to welding.
- C. Membrane surfaces to be welded shall be clean and dry.
- D. Extend deck membrane onto vertical surfaces as recommended by manufacturer but no less than 2 inches minimum.
- E. Penetration Openings and Cut-Outs:
  - 1. Cut membrane to fit closely around roof penetrations.
  - 2. Secure membrane to substrate with approved fasteners and plates at 12 inches on centers, minimum.
  - 3. Field weld prefabricated skirt or penetration accessories to membrane to create watertight seal at penetrations.
  - 4. Tighten clamp or band around pipe or curb, or
  - 5. Secure top of penetration accessory with termination bar.
  - 6. Apply approved sealant to top of clamp, band or termination bar

### 3.5 HOT-AIR WELDING OF SEAM OVERLAPS

- A. General:
  - 1. Seams shall be hot-air welded. Seam overlaps shall be per manufacturer's recommendations.
  - 2. Welding equipment shall be provided by or approved by membrane manufacturer. Mechanics intending to use the equipment shall have successfully completed a training course provided by the manufacturer prior to welding.
  - 3. Membrane to be welded shall be clean and dry.
  - 4. Tack welding of the membrane is not allowed. Seams shall be completely hot air welded.
  - 5. Seam overlaps should be 3 inches (75 mm) wide when automatic machine-welding and 4 inches (100 mm) wide when hand-welding, except for certain details
- B. Hand-Welding:
  - 1. Hand-welded seams shall be completed in two stages. Hot-air welding equipment shall be allowed to warm up for at least one minute prior to welding.
  - 2. The back edge of the seam shall be welded with a narrow but continuous weld to prevent loss of hot air during the final welding.
  - 3. The nozzle shall be inserted into the seam at a 45 degree angle to the edge of the membrane. Once the proper welding temperature has been reached and the membrane begins to "flow," the hand roller shall be positioned perpendicular to the nozzle and rolled lightly. For straight seams, use the 1-1/2 inch (40 mm) wide nozzle. For corners and compound connections, use the 3/4 inch (20 mm) wide nozzle.

- C. Machine Welding:
1. Machine welded seams are achieved by the use of PVC manufacturer's approved robotic hot air welding machine.
  2. Applicable building local and OSHA codes for electric supply, grounding and over current protection observed. Dedicated circuit house power or a dedicated portable generator is recommended. No other equipment shall be operated off the generator.
  3. Metal tracks shall be used over the deck membrane and under the machine welder to minimize or eliminate wrinkles along the seam.
- D. Quality Control of Welded Seams:
1. The Applicator shall check welded seams for continuity using a rounded screwdriver. Visible evidence that welding is proceeding correctly is smoke during the welding operation, shiny membrane surfaces, and an uninterrupted flow of dark grey material from the underside of the top membrane.
  2. On-site evaluation of welded seams shall be made daily and every time the heat welder is turned off and on by the Applicator at locations as directed by the Owner's Representative or PVC Manufacturer's representative.
  3. One inch (25-mm) wide cross-section samples of welded seams shall be taken at least three times a day by the Contractor from various locations.
  4. Contractor shall label each seam test cut with the time, date, and location of the test cut. Provide roof plan with test cuts clearly labeled on plan.
  5. Retain test cuts on site until final project close-out for the Owner's representative's and PVC manufacturer's technical representative's inspection and evaluation.
  6. Correct welds display failure from shearing of the membrane prior to separation of the weld.
  7. Repair tears, voids, and lapped seams in roofing that does not meet requirements.
  8. Each test cut shall be patched by the Applicator at no extra cost to the Owner.
  9. Membrane seams, both field and flashings, shall be hot air welded and probed daily.

### 3.6 FLASHINGS AND ACCESSORIES

- A. General: Flashings shall be installed concurrently with the roof membrane as the job progresses. No temporary flashings shall be allowed without the prior written approval of the Owner's Representative and the manufacturer. Approval shall only be for specific locations on specific dates. Flashing shall be adhered to compatible, dry, smooth, and solvent-resistant surfaces. Use caution to ensure adhesive fumes are not drawn into the building.
- B. PVC/KEE Manufacturer's approved adhesive shall be used to adhere the PVC/KEE membrane flashing to acceptable wall and equipment curb substrates. No bitumen shall be in contact with the PVC/KEE membrane. If bitumen exists, then the manufacturer's asphalt resistant membrane shall be used for the membrane flashing.
- C. PVC/KEE Manufacturer's Approved Adhesive for Membrane Flashings:
1. Over the properly installed and prepared flashing substrate, contact adhesive shall be applied per instructions found on the Product Data Sheet. The adhesive shall be applied in smooth, even coats with no gaps, globs or similar inconsistencies. Only an area that can be completely covered in the same day's operations shall be flashed. The bonded sheet shall be pressed firmly in place with a hand roller.

2. No adhesive shall be applied in seam areas that are to be welded. Panels of membrane shall be applied in the same manner, overlapping the edges of the panels as required by welding techniques.
  3. Flashing membranes shall be consistently adhered to substrates. Interior and exterior corners and miters shall be cut and hot-air welded into place. Where applicable, manufacturer's pre-fabricated corners shall be used.
- D. Flashings shall not be placed in direct contact with bituminous self-adhered underlayment.
  - E. Flashings shall extend a minimum of 8-inches (0.2 m) above roofing level unless otherwise indicated in the Contract Documents or accepted in writing by the Owner's Representative and PVC/KEE Manufacturer's Technical Department.
  - F. Flashings that exceed 30 inches (0.75 m) in height shall receive additional securement. Consult PVC/KEE manufacturer for securement methods.
  - G. PVC/KEE membrane flashings shall be mechanically fastened along the counter-flashed top edge with securement bar; fastened 6-8 inches on center. Seal the top edge and backside of the membrane flashing with Multi-Purpose Sealing Tape and approved sealant. Complete termination per manufacturer's requirements. Provide a metal counterflashing to protect the sealant and multi-purpose sealant tape.
  - H. Only an area, which can be completely covered in the same day's operations, shall be flashed.
  - I. Daily test lap edges with probe to verify seam weld continuity of membrane flashings.
  - J. Complete membrane flashing and metal flashing details daily. If any water is allowed to enter under the completed roofing due to incomplete flashings, the affected area shall be removed and replaced at the Applicator's expense.
- 3.7 PVC/KEE COATED CLAD METAL BASE FLASHINGS
- A. General: Flashings shall be installed concurrently with the roofing membrane as the job progresses. No temporary flashings shall be allowed without the prior written approval of the Owner's Representative and the manufacturer. Acceptance shall only be for specific locations on specific dates. If any water is allowed to enter under the newly completed roofing due to incomplete flashings, the affected area shall be removed and replaced at the Applicator's expense.
  - B. PVC/KEE coated metal flashings shall be formed per Contract Documents to match existing conditions and installed per the Detail Drawings.
  - C. PVC/KEE coated metal shall be installed to provide adequate resistance to bending and allow for normal thermal expansion and contraction.
  - D. Install Multi-purpose sealant tape and termination bar as indicated on project details. The Multi-purpose sealant tape must be applied to clean and dry surfaces.
  - E. Secure the PVC/KEE coated metal over the PVC/KEE field membrane and the multi-purpose sealant tape. Fasten the PVC/KEE coated metal with approved stainless-steel

nails or other acceptable fasteners. Fasteners shall be fastened 4-inches on center and staggered 4-inches on center.

- F. Adjacent sheets of PVC/KEE coated metal shall be spaced  $\frac{1}{4}$  inch (6 mm) apart. The joint shall be covered with 2-inch (50-mm) wide aluminum tape. A 4-inch minimum wide strip of PVC/KEE membrane flashing membrane shall be hot air welded over the joint. Check cover-strip welds with a rounded screwdriver prior to installation of eight-inch coverstrip. Re-weld any inconsistencies before eight-inch coverstrip installation.
- G. An 8-inch minimum wide strip of the 60 mil PVC/KEE membrane flashing shall be hot air welded to the 4-inch wide flange of the PVC/KEE coated metal and to the field membrane. Check cover-strip welds with a rounded screwdriver. Re-weld any inconsistencies.

### 3.8 WALKWAY PAD INSTALLATION

- A. General Requirements:
  - 1. Install walkway pads according to walkway manufacturer's written instructions.
  - 2. Pads cut from rolls shall be allowed to relax for 24 hours prior to installation.
  - 3. Set walkway pads in cold-applied adhesive or by torch application.
  - 4. Locations:
    - a. For modular pads, provide a minimum of two pads adjacent to plus 12 inches beyond electrical disconnect racks and roof ladder landings, around all sides of mechanical equipment, and on three sides of each roof hatch.
    - b. For roll pads, match the width plus 12 inches beyond electrical disconnect racks and roof ladder landings, continuous around all sides of mechanical equipment, and continuous around three sides of each roof hatch.
  - 5. Modular pads shall be set with a 3-inch gap for drainage.

### 3.9 FIELD QUALITY CONTROL

- A. Roofing Applicator: The contractor shall make On-site evaluation of welded seams to locations as directed by the owner's representative or PVC manufacturer's technical representative. Two-inch wide cross-sections samples shall be taken three times a day minimum through completed seams. Correct welds shall display failure from shearing the membrane prior to separation of weld. The contractor at no extra charge to owner shall patch each test cut. Test seam samples shall be labeled with locations of seam cut, date of seam cut, and retained on-site for owner's representative or PVC manufacturer's technical representative for test cut inspections. At the close of project, seam test cuts are to be submitted to the owner's representative for review.
- B. Final Roof Inspection: Arrange for roofing system manufacturer's technical personnel to inspect roofing installation on completion of the roofing project.
  - 1. Defects noted non-compliance with the specifications, or the recommendations of the thermoplastic manufacturer should be itemized in a punch list. These items must be corrected immediately by the contractor to the satisfaction of the owner's representative and the PVC Manufacturer.
  - 2. A copy of Final Inspection Report shall be sent to the Owner's Representative within two days after date inspection(s) is performed.

### 3.10 MANUFACTURER'S FIELD SERVICES

- A. Provide manufacturer's field services under provisions of the appropriate Division 01 Section and Part 1 of this Section..

### 3.11 PROTECTION AND CLEANING

- A. Protect sheet membrane roofing from damage and wear during the construction period. Installer is to inspect the completed roofing system for any damage and repair damages found in the roofing system.
- B. Correct deficiencies in or remove roofing that does not comply with requirements, repair substrates, reinstall roofing, and repair sheet flashings to a condition free of damage and deterioration at the time of Substantial Completion and per warranty requirements.
- C. Upon completion of the Work of this Section, dispose of, away from the Site, debris, trash, containers, residue, roofing remnants and scraps.
- D. Remove bituminous markings and stains from the finished membrane surface.
- E. The completed Roof shall be washed with water and approved cleaner to remove dirt and residue from roof membrane.

### 3.12 TEMPORARY CUT-OFF AND PROTECTION

- A. Protect new and existing roof surfaces from damage by other trades.
- B. Where traffic must traverse existing roofs, provide a protective covering consisting of plywood sheets secured to a layer of 1/2-inch wood fiber insulation board and laid loose over the membrane with the insulation board side to the roof surface.
  - 1. Do not store materials on the roof without this protective covering.
  - 2. Any damage to new or existing roofs shall be repaired at the Contractor's cost per requirements of the manufacturer holding or providing the current Warranty.
- C. Flashings shall be installed concurrently with the membrane in order to maintain a watertight condition as the work progresses. When a break in the day's work occurs in the installation of the roofing system, the roofing contractor shall install a temporary watertight seal. The roofing membrane shall be sealed to the substrate so that water will not be allowed to travel into or under the new or existing Roofing. When work resumes, the contaminated membrane shall be removed from the work area and disposed off site. None of these materials shall be reused in the new work.
- D. If inclement weather occurs while a temporary water stop is in place, the contractor shall provide the labor and materials to monitor the temporary water stop and to maintain a watertight condition.
- E. If any water can enter under the newly completed Roofing, the affected area shall be removed and replaced at the contractor's expense.
- F. Protect completed roofing system from damage and wear during remainder of construction period. When remaining construction will not affect or endanger roofing, inspect roofing for deterioration and damage, describing its nature and extent in a written report, with copies to Architect and Owner.

- G. Correct deficiencies in or remove roofing system that does not comply with requirements, repair substrates, and repair or reinstall roofing system to a condition free of damage and deterioration at time of Substantial Completion and according to warranty requirements.

END OF SECTION 07 5565

SECTION 07 5800

ELASTOMERIC ROOF COATING

PART 1 - GENERAL

1.1 RELATED DOCUMENTS

- A. Drawings and general provisions of the Contract, including General and Supplementary Conditions and other Division 01 Specification Sections, apply to this Section.

1.2 SUMMARY

- A. Section Includes:
  - 1. Elastomeric roof coating – primer and finish coats.
- B. Related Sections
  - 1. Section 01 7830 - Roofing Installer's Warranty

1.3 WORK INCLUDED

- A. Elastomeric coating of existing granular surfaced modified bitumen membrane with the following warranties:
  - 1. Roof Sections: A02, A04, A05, A07, A09, A10, A11, A12, A14, A15, A16, A17, B02, B06, B07.
    - a. Existing 20-year manufacturer's warranty by GAF.
    - b. Expiration: 09/20/2026.
  - 2. All Work shall meet the standards of and match existing warranted roof systems currently on the buildings

1.4 SUBMITTALS

- A. Comply with provisions of Division 01.
- B. Mark each product data cut-sheet by circling or highlighting and affix the corresponding Article and Paragraph numbers from this Specification Section. Product data not so marked will be returned without review, for re-submittal complying with the above requirements.
- C. Product Data: For each type of product indicated. Include installation sequence, special instructions and Material Safety Data Sheets (MSDS) for materials.
- D. Manufacturer's Certification: Provide current letter(s) on coating manufacturer's letterhead, signed by an authorized employee or corporate officer attesting to the following:
  - 1. Products: Certify that roofing system complies with requirements of this Section.
  - 2. Coating system components are physically and chemically compatible for installation as designed.
  - 3. Proposed materials, including those by other manufacturer, are acceptable to membrane manufacturer for use in system.
  - 4. Proposed system meets criteria for continuance of existing manufacturer's warranty.
  - 5. Specifically identify and define any deviations.



- E. Installer Certificates: Signed by coating system manufacturer certifying that Installer is approved, authorized, or licensed by manufacturer to install roofing system.
- F. Manufacturer's Field Reports: Summarize findings of each inspection. Indicate any discrepancies from recommended installation methods, corrective action recommended to installer, and any non-compliant or unsatisfactory conditions.

#### 1.5 QUALITY ASSURANCE

- A. Manufacturer: Manufacturer currently holding warranty of existing roof system.
- B. Applicator: Work may be performed by any roofing contractor approved for a minimum of 3 years prior to bid date for repair of the following 20-year NDL warranted systems: GAF.
- C. Perform Work in adherence to manufacturer's requirements to prevent voiding existing warranties.
- D. Source Limitations: Obtain components for coating system from or approved by roofing system manufacturer.
- E. Perform Work in accordance with NRCA Manual of Roof Maintenance and Roof Repair, NRCA Roofing and Waterproofing Manual, and manufacturer's instructions.
- F. Workers: All roofers and laborers to be direct employees of Primary Contractor.
  - 1. Project Manager and Superintendent: Minimum five years roofing experience and employed by Contractor for a minimum one year prior to Bid Date.
  - 2. Non-working Supervisor: Able to communicate effectively with School staff and Applicator's workers and employed by Contractor for a minimum one year prior to Bid Date.
  - 3. Tradesmen: Minimum 50-percent of installation crew to have been employed by Contractor for a minimum six months prior to Bid Date.
- G. Assign a qualified, full time, non-working supervisor to be on Project site always during installation of Work.
- H. Do not allow materials which have not been approved through the submittal process to be brought onto the project site. Any materials brought onto the site which have not been approved through the submittal process will be rejected and shall be removed immediately. Remove - without appeal or exception - any materials incorporated into the Work that have not been approved through the specified submittal process.
- I. The manufacturer's representative shall make a minimum of two (2) site visits to the project per month at critical stages of the coating installation, and forward to the Architect written reports of the observations and instructions given to the Contractor during these visits. Coordinate the visits to take place at the time of the Architect's visits, with one occurring at the monthly pay application meeting. Include at the minimum the following information in manufacturer's representative's reports:
  - 1. Prepare reports typewritten on the manufacturer's letterhead stationery and submit to the Architect within seven (7) days of the site visit.
  - 2. Document Work in progress and list deficiencies, corrective actions and recommendations.
  - 3. Failure of the manufacturer's representative to provide the required reports in a

timely manner is cause for rejection of the Contractor's pay application.

J. Substantial Completion:

1. Upon substantial completion of the Work arrange for a final inspection of the coating work by the manufacturer's representative. Provide correction of all items noted during this inspection.
2. The final manufacturer's rep's inspection shall be timed to coincide with the Architect's Substantial Completion inspection.

1.6 PRE-INSTALLATION CONFERENCE

- A. Attend a pre-installation conference among the parties directly affecting the Work of this Section a minimum of two weeks prior to the start of Work under this Section.
- B. Required Attendees: Contractor's Project Manager and Superintendent; Mechanical, Plumbing and Electrical Trades Representatives; Manufacturer's Field Technical Representative; Owner's Representative(s); Architect and/or his designated representative(s).
- C. The Agenda: A review of submittals, general procedures for the Work, installation procedures, progress of the Work, and coordination with related trades.
- D. Produce accurate and comprehensive written minutes of the meeting and distribute copies to each party.

1.7 DELIVERY, STORAGE AND HANDLING

- A. Deliver coating materials to Project site in original containers with seals unbroken and labeled with manufacturer's name, product brand name and type, date of manufacture, approval or listing agency markings, and directions for storing and mixing with other components.
  1. Inspect for damage. Replace damaged or deteriorated materials.
  2. Store products in weather protected environment, clear of ground and moisture.
  3. Stand and store roll materials on ends.
- B. Store liquid materials in their original undamaged containers in a clean, dry, protected location and within the temperature range required by roofing system manufacturer. Protect stored liquid material from direct sunlight.
  1. Discard and legally dispose of liquid material that cannot be applied within its stated shelf life.

1.8 PROJECT CONDITIONS

- A. Weather Limitations: Proceed with installation only when existing and forecasted weather conditions permit roofing system to be installed per manufacturer's written instructions and warranty requirements.
  1. Do not apply roofing membrane during inclement weather.
  2. Do not apply roofing membrane to damp or frozen deck surface.
  3. Observe wind chill and other cold weather conditions for proper bituminous application.
- B. Do not apply any portion of the coating system or its accessories, or start operations in the

event precipitation is threatening, unless proper precautions are taken for same. The Contractor shall have the final decision as to whether to chance roofing operations in the event wet conditions threaten and shall consider wind speed as a determining factor as to whether roofing operations can be safely accomplished under such conditions. The Contractor shall suspend Work if, in his/her opinion, wind speed will impede the proper installation of the coating Work, or cause a danger to his/her personnel, or to the Owner's property.

#### 1.9 SEQUENCING AND SCHEDULING

- A. Coordinate Work under provisions of the appropriate Division 01 Section regarding administrative requirements.
- B. Coordinate with demolition Work and with Work of other trades to ensure sufficient materials and manpower are available to complete coating Work each day.
- C. Schedule Work to avoid storage on and traffic over finished Work.

#### 1.10 WARRANTY

- A. Provide a two-year written warranty covering defects in the roofing materials and labor, on the form in Section 01 7830.
- B. Provide a ten-year manufacturer's warranty covering material and labor.
- C. Commence warranties on the Date of Substantial Completion for the overall project.

### PART 2 - PRODUCTS

#### 2.1 MANUFACTURERS

- A. GAF

#### 2.2 COATING MATERIALS

- A. Products of GAF:
  - 1. Primer: EnergyCote Roof Coating.
  - 2. Finish Coat: Unibase Primer.

### PART 3 - EXECUTION

#### 3.1 INSPECTION

- A. Examine the Contract Documents and all conditions which affect the quality of the Work. Deviations or unsatisfactory conditions shall be reported to the Architect in writing. No Work shall proceed until conditions are satisfactory to meet requirements of the Contract Documents.

#### 3.2 PREPARATION

- A. Review the Contract Documents to determine and locate all Work required by this Section and the Work of any other trade which affects the Work.
- B. Do not brush/spray over roof drainage devices, copings, metal counterflashings, service utility lines or other materials not intended to be coated. Immediately clean any overspray to the satisfaction of the Owner.

### 3.3 SUBSTRATE PREPARATION

- A. Sweep and remove all loose materials and granules from the roof surface.
- B. Prepare roof surface per manufacturer's instructions.
- C. Substrate must be clean, completely dry and free of any debris before application of coating products.
- D. Apply primer per manufacturer's recommendations.
- E. Provide test patches in three (3) locations to determine adhesion of new materials. Consult manufacturer for satisfactory results.
- F. Repair damaged roof membrane per manufacturer's recommendations.

### 3.4 COATING APPLICATION

- A. Comply strictly with manufacturer's written recommendations.
- B. Apply one coat over all seams and joints. Allow to cure for one hour or until dry.
- C. Apply base coat at the rate of 1.5 gallons per 100 sf. Allow 4 hours drying time and inspect the base coat for defects, flaws, or holidays. Correct any unsatisfactory conditions prior to proceeding with finish coat.
- D. Apply finish coat at the rate of 1.5 gallons per 100 sf. Finish coat shall not be applied unless the base coat is clean and will provide proper adhesion.

### 3.5 CLEANING

- A. Clean all grounds, roofing surfaces and metal flashings free of overspray materials. Remove all excess materials.
- B. Re-install materials which may have been removed during the Work and ensure all to be in working order.
- C. Remove temporary fencing and restore grounds to condition prior to Work. Replace any permanently damaged vegetation as required.

END OF SECTION 07 5800

SECTION 07 7200

ROOF ACCESSORIES

PART 1 - GENERAL

1.1 RELATED DOCUMENTS

- A. Drawings and general provisions of the Contract, including General and Supplementary Conditions and other Division 01 through Division 26 Specification Sections, apply to this Section.

1.2 SUMMARY

- A. Section Includes:
  - 1. Pipe supports.
  - 2. Roof curbs.
  - 3. Equipment supports.
  - 4. Duct supports.
- B. Related Sections
  - 1. Section 07 5565 - Thermoplastic Overlay Roof System
  - 2. Section 07 6200 - Flashing and Sheet Metal
  - 3. Section 22 0000 - Common Work Results for Plumbing
  - 4. Section 23 0000 - Common Work Results for Mechanical
  - 5. Section 26 0000 - Common Work Results for Electrical

1.3 PERFORMANCE REQUIREMENTS

- A. General Performance: Roof accessories shall withstand exposure to weather and resist thermally induced movement without failure, rattling, leaking, or fastener disengagement due to defective manufacture, fabrication, installation, or other defects in construction.
- B. Structural Performance of Duct Supports: Duct support bases, posts, crossbars and connections shall withstand the effects of loads and stresses within limits and under conditions specified in currently enforced edition of IBC and related references to ASCE 7 and FM standards.

1.4 SUBMITTALS

- A. Comply with provisions of Division 01.
- B. Mark each product data cut-sheet by circling or highlighting and affix the corresponding Article and Paragraph designations from this Specification Section. Product data not so marked will be returned without review, for re-submittal complying with the above requirements.
- C. Product Data: For each type of roof accessory indicated. Include construction details, material descriptions, dimensions of individual components and profiles, and finishes.
- D. Submit shop drawings for duct supports sealed by a professional engineer licensed in

the State of Texas.

- E. Submit sample warranties for all products listed in Article 1.6.

#### 1.5 DELIVERY, STORAGE, AND HANDLING

- A. Materials shall be delivered in bulk as necessary without hindrance of the Work.
  - 1. Schedule and coordinate with Owner necessary deliveries to cause the least amount of inconvenience to Owner's daily activities.
  - 2. Deliveries and unloading or loading activities shall be the responsibility of the Contractor. The Owner will not take any responsibility for Contractor's deliveries.
- B. Store necessary materials in such a manner to keep from damage by elements or construction and other traffic. Storage of materials on the roof surface is prohibited without adequate blocking to prevent damage to the existing or new roof surfaces.
- C. Fit accessory Work to other Work. Scribe and cope as required for accurate fit.

#### 1.6 WARRANTY

- A. Pipe Supports: Provide manufacturer's standard warranty.
- B. Roof Curbs: Provide manufacturer's standard warranty.
- C. Equipment Supports: Provide manufacturer's standard warranty.
- D. Duct Supports: Provide manufacturer's standard warranty.

### PART 2 - PRODUCTS

#### 2.1 PIPE SUPPORTS

- A. General:
  - 1. Reuse of existing supports or support pads is not acceptable.
  - 2. Construction trades including plumbing, mechanical and electrical shall provide pipe supports from the same manufacturer.
  - 3. Piping supported on the roof surfaces shall be one of the systems specified herein, with the hardware for each system being provided by this Contractor.
  - 4. Furnish and install curbs and flashings, traffic support pads, sheet metal flashings, etc., as required for the proper installation of these systems.
  - 5. Piping and conduit should be elevated a minimum of 12 inches above the roof surface, unless otherwise noted.
  - 6. Piping and conduit should be clamped down with retainer brackets or channel clamps.
- B. Pipe Support – Type "A": Provide for support of single condensate lines 1-1/2 inch outside diameter and less, and PVC lines.
  - 1. Manufacturer / Model(s):
    - a. Vent Caddy (ERICO), [www.ericocom.com](http://www.ericocom.com) or approved equal.
      - 1) Pyramid ST Fixed Strut Support (Where positive slope is provided in structure / roofing system.)
      - 2) Pyramid ST Adjustable Strut Support (Where positive slope is not

- provided in structure / roofing system.)
- b. OMG Roofing Products, [www.omgroofing.com](http://www.omgroofing.com) or approved equal.
    - 1) OMG Pipeguard® 'Mini' (Where positive slope is provided in structure / roofing system.)
    - 2) OMG Pipeguard® 'Height Adjustable Strut' (Where positive slope is not provided in structure / roofing system.)
  - c. PHP Systems/Design, [www.phpsd.com](http://www.phpsd.com) or approved equal.
    - 1) SS8-CL (Where positive slope is provided in structure / roofing system.)
    - 2) SS8-C (Where positive slope is not provided in structure / roofing system.)
2. Support assembly is to be composed of:
    - a. Base: Molded polyethylene and/or polypropylene base with UV inhibitors.
    - b. Rod: Galvanized steel 1/2"Ø threaded rods, nuts and washers.
    - c. Channel: Galvanized steel 12-gauge channel.
    - d. Bracket: Galvanized steel retainer bracket.
  3. Space supports at maximum distance of 8'-0" on center or less to prevent sag or deflection.
  4. Place supports within 12 to 18 inches of "ell" corners, pipe bends, tee intersections and below each pipe or conduit joint.
- C. Pipe Support – Type "B": Provide for support of single hydronic pipe / gas pipe / electrical conduit 2 inch outside diameter and less.
1. Manufacturer / Model(s):
    - a. PHP Systems/Design, [www.phpsd.com](http://www.phpsd.com) or approved equal.
      - 1) Hydronic Pipe: PP-10-R with roller support and insulation shield.
      - 2) Gas Pipe: PP-10-R with roller support.
      - 3) Electrical Conduit: PP-10-C with channel.
  2. Support assembly is to be composed of:
    - a. Base: Molded high density/high impact polypropylene base with UV inhibitors and antioxidants.
    - b. Base Footprint: 10" x 16" minimum.
    - c. Rod: Galvanized steel 1/2"Ø threaded rods, nuts and washers.
    - d. Roller: Cast iron roller with malleable sockets (gas pipe only). Nylon or synthetic compound rollers are not acceptable.
    - e. Channel: Galvanized steel 12-gauge channel (electrical conduit only).
    - f. Bracket: Galvanized steel retainer bracket.
    - g. Insulation Shield: Galvanized steel.
  3. Space supports at maximum distance of 8'-0" on center or less to prevent sag or deflection where piping or conduit is greater than 1-1/4 inches outside diameter.
  4. Space supports at maximum distance of 6'-0" on center or less to prevent sag or deflection where piping or conduit is equal to or less than 1-1/4 inches outside diameter.
  5. Place supports within 12 to 18 inches of "ell" corners, pipe bends, tee intersections and below each pipe or conduit joint.
  6. Provide retainer bracket to prevent pipe from lifting from the rollers.

- D. Pipe Support – Type “C”: Provide for support of single or multiple hydronic pipes / gas pipes / electrical conduits greater than 2 inch outside diameter and equal to or less than 3-1/2 inch outside diameter.
1. Manufacturer / Model(s):
    - a. PHP Systems/Design, [www.phpsd.com](http://www.phpsd.com) or approved equal.
      - 1) PS-1-2 (single pipe/conduit)
      - 2) PSE-2-2 or PSE Custom (multiple pipes/conduits)
      - 3) Provide roller trapeze for hydronic and gas pipe and clevis trapeze for electrical conduit.
      - 4) Provide insulation shield for hydronic piping.
    2. Support assembly is to be composed of:
      - a. Base: Molded high density/high impact polypropylene base with UV inhibitors and antioxidants.
        - 1) Model PS-1-2: 12” x 12” x 3”
        - 2) Model PSE-2-2 or PSE Custom: 18” x 18” x 3”
      - b. Frame: Galvanized steel 12-gauge channel with galvanized brackets bolted to strut and mounted with galvanized steel bolts through neoprene washers into metal-capped curb assembly.
    - c. Rod: Galvanized steel 1/2"Ø threaded rods, nuts and washers.
    - d. Hanger: Galvanized steel trapeze.
    - e. Roller: Cast iron roller with malleable sockets. Nylon or synthetic compound rollers are not acceptable.
    - f. Insulation Shield: Galvanized steel.
  3. Space supports at maximum distance of 8'-0" on center or less to prevent sag or deflection.
  4. Place supports within 12 to 18 inches of “ell” corners, pipe bends, tee intersections and below each pipe or conduit joint.
- E. Pipe Support – Type “D”: Provide for support of single or multiple hydronic pipes / gas piping / electrical conduit in excess of 3-1/2 inch outside diameter.
1. Manufacturer / Model(s):
    - a. Eaton (formerly Cooper Industries), [www.eaton.com](http://www.eaton.com) or approved equal.
      - 1) B-Line Series base/pipe stand, adjusters and supports, as detailed.
      - 2) Provide insulation shield for hydronic piping.
  2. Support assembly is to be composed of:
    - a. Frame: Galvanized steel 12-gauge channel with galvanized brackets welded to strut and mounted with galvanized steel bolts through neoprene washers into metal-capped curb assembly.
    - b. Rod: Galvanized steel 1/2"Ø threaded rods, nuts, axle and retainer bracket.
    - c. Roller: Cast iron roller with malleable sockets. Nylon or synthetic compound rollers are not acceptable.
    - d. Bracket: Galvanized steel retainer bracket.
    - e. Insulation Shield: Galvanized steel.
  3. Space supports at maximum distance of 8'-0" on center or less to prevent sag or



- deflection.
4. Place supports within 12 to 18 inches of “ell” corners, pipe bends, tee intersections and below each pipe or conduit joint.
- F. Pipe Support – Type “E”: Provide for support of existing single or multiple hydronic pipes and electrical conduit 2 inch outside diameter and less.
1. Manufacturer / Model(s):
    - a. PHP Systems/Design, [www.phpsd.com](http://www.phpsd.com) or approved equal.
      - 1) PP-10 with trapeze hangers.
      - 2) Provide insulation shield for insulated piping.
    2. Support assembly is to be composed of:
      - a. Base: Molded high density/high impact polypropylene base with UV inhibitors and antioxidants.
      - b. Base Footprint: 10” x 16” minimum.
      - c. Rod: Galvanized steel 1/2"Ø threaded rods, nuts and washers.
      - d. Hanger: Galvanized steel trapeze.
      - e. Channel: Galvanized steel 12-gauge channel (electrical conduit only).
      - f. Insulation Shield: Galvanized steel.
    3. Space supports at maximum distance of 8'-0" on center or less to prevent sag or deflection.
    4. Place supports within 12 to 18 inches of “ell” corners, pipe bends, tee intersections and below each pipe or conduit joint
- G. Small Electrical Conduit:
1. Electrical conduit of 1 inch outside diameter and smaller shall be placed in a run of galvanized steel Unistrut channel laid across the top of curbs or Type “B” pipe supports
  2. Ends of channels and corners shall be connected with bolted plates.
  3. Secure channels by 16-gauge galvanized steel straps to the curbs or supports.
- H. Pipe Support Protection Pads:
1. Type A, B, C and E: Protection pad below pipe support base.
    - a. Johns Manville: JM PVC: 80 mil
    - b. Sika: Sarnafil G410: 80 mil
    - c. Siplast: ParaSolo PVC KEE: 80 mil
    - d. Soprema: Sentinel P200 HFB: 80 mil

## 2.2 ROOF CURBS

- A. Pre-manufactured Steel Curbs: Internally reinforced metal equipment supports capable of supporting superimposed live and dead loads, including equipment loads and other construction indicated on Drawings.
1. Manufacturer: Thybar Corp., [www.thybar.com](http://www.thybar.com) or approved equal.
  2. Model: Model TC-3.
  3. Shop Fabrication: Shop fabricated curbs are not acceptable.
  4. Coordinate with Mechanical Contractor as to which mechanical equipment is being provided with pre-manufactured curbs. If so, those curbs shall be installed by the Mechanical Contractor; flashing, counterflashing and sealing of roof system to the curbs shall be by Roofing Contractor.

- B. Construction:
1. Frames: 18-gauge G90 hot-dipped galvanized sheet steel and base plate with joints fully welded complying with ASTM A653. Bolted connections are not acceptable.
  2. Wood Nailers: Factory installed; pressure treated. Size and width as suitable for support of mechanical equipment mounted on curbs.
  3. Reinforcement: Internally reinforce curbs exceeding 3-foot length and as required to support mechanical equipment.
  4. Gasketing: ¼-inch thick x 1-inch wide at rooftop units.
  5. Counterflashing: As indicated on the drawings.
  6. Insulation: 1-1/2" thick 3-pound density rigid insulation.
  7. Curb Height: Coordinate curb height to comply with roofing drawings. Minimum height above roof surface shall be measured from the highest side of sloped roof.
  8. Roof Slope: Curbs shall be constructed to match roof slope with plumb and level top surface for mounting mechanical equipment.

## 2.3 EQUIPMENT SUPPORTS

- A. Equipment Supports: Internally reinforced metal equipment supports capable of supporting superimposed live and dead loads, including equipment loads and other construction indicated on Drawings.
1. Manufacturer: Thybar Corp., [www.thybar.com](http://www.thybar.com) or approved equal.
  2. Model: Model TEMS-3.
  3. Size: Coordinate dimensions with roughing-in information or Shop Drawings of equipment to be supported.
  4. Shop Fabrication: Shop fabricated equipment supports are acceptable if they meet the requirements of the specifications and drawings.
  5. Coordinate with mechanical contractor to determine if any equipment supports are being furnished with respective equipment. If so, those curbs shall be installed by the Mechanical Contractor; flashing, counterflashing and sealing of roof system shall be by Roofing Contractor.
- B. Construction:
1. Material: Galvanized steel sheet, 18 gauge with welded joints.
  2. Insulation: Fill curb with fiberglass batt insulation.
  3. Factory-installed continuous wood nailers at tops of equipment supports.
  4. Provide a 24-gauge galvanized sheet metal cap with fully soldered or welded joints.
    - a. Secure caps with stainless steel screws with neoprene-head washers spaced at 16-inches on center max. with a minimum of two screws on each side.
    - b. Curb sides with dimensions of less than 8 inches require one fastener per side.
  5. Fabricate equipment supports to minimum height of 12 inches above the finished high side roof surface unless otherwise indicated.
  6. Roof Slope: Equipment supports shall be constructed to match roof slope with plumb and level top surface for mounting equipment.

## 2.4 DUCT SUPPORTS

- A. General:
1. Reuse of existing duct supports or support pads is not acceptable.
  2. Construction trades including mechanical shall provide duct supports from the

- same manufacturer.
3. Ductwork supported on the roof surfaces shall be one of the systems specified herein, with the hardware for each system being provided by this Contractor.
  4. Furnish and install curbs and flashings, traffic support pads, sheet metal flashings, etc., as required for the proper installation of these systems.
  5. Ductwork should be elevated a minimum of 12 inches above the roof surface, unless otherwise noted.
- B. Manufacturer/Model: PHP Systems/Design, [www.phpsd.com](http://www.phpsd.com) or approved equal; Model PHP-D 'Goal-Post' style.
- C. Design Conditions:
1. Support Spacing: As required for actual field conditions and confirmed by manufacturer's engineer sealed shop drawings, but not greater than 6 feet on center.
  2. Protection Pads for Thermoplastic Roofing: Provide protection pads below support bases as detailed and as follows:
    - a. Johns Manville: JM PVC: 80 mil
    - b. Sika Sarnafil:G410: 80 mil
    - c. Siplast: ParaSolo PVC KEE: 80 mil
    - d. Soprema: Sentinel P200 HFB: 80 mil
- D. Support assembly is to be composed of:
1. Base: Molded high density/high impact polypropylene base with UV inhibitors and antioxidants.
  2. Frame: Galvanized steel 12-gauge perforated channel with galvanized brackets bolted to strut and mounted with galvanized steel bolts.

### PART 3 - EXECUTION

#### 3.1 INSTALLATION - GENERAL

- A. Inspect existing conditions to determine that Work preceding this installation is as intended and is of sound construction. Proceeding with the Work of this Section indicates acceptance of conditions.
- B. Installations shall be in accordance with the manufacturer's printed instructions and as shown on the Drawings.

#### 3.2 PIPE SUPPORT INSTALLATION

- A. Non-Penetrating Pipe Supports (Types A, B & C):
1. Assemble pipe supports with protection pad as shown on the Drawings. Adhere supports solid to protection pads in specified sealant.
  2. Set pad assemblies on the modified bitumen roof membrane. Do not adhere to roof system.
  3. Securely strap electrical conduit or Unistrut carrying electrical conduit to supports with galvanized steel straps.
  4. Loosely strap gas piping to support with galvanized steel straps. Straps shall allow free movement of piping, but not allow piping to lift more than 1 inch from support.

- B. Penetrating Curbed Roller Pipe Supports (Type D):
  - 1. Anchor new curbs to existing deck or wood blocking using #12 coated insulation screws spaced at 8 inches on center, or a minimum of two per side.
  - 2. Flash curbs to the roof per the respective Section.
  - 3. Set new galvanized metal caps as shown on the Drawings.
  - 4. Set new roller assemblies and anchor securely to curbs with neoprene-head screws.
  - 5. Strap tops of pipes to roller assemblies.

### 3.3 OTHER ASSEMBLY INSTALLATION

- A. Equipment Supports and Curbs: Anchor supports and curbs to deck or wood blocking as shown on the Drawings using #12 coated insulation screws or lag bolts spaced at 8-inches on centers, or minimum of two per side.
- B. Other Assemblies: Install as indicated on the Drawings, as required by the manufacturer or as designated above.

### 3.4 CLEANING

- A. Clean items of this Section in accordance with the respective manufacturer's instructions.

END OF SECTION 07 7200

# AUSTIN INDEPENDENT SCHOOL DISTRICT

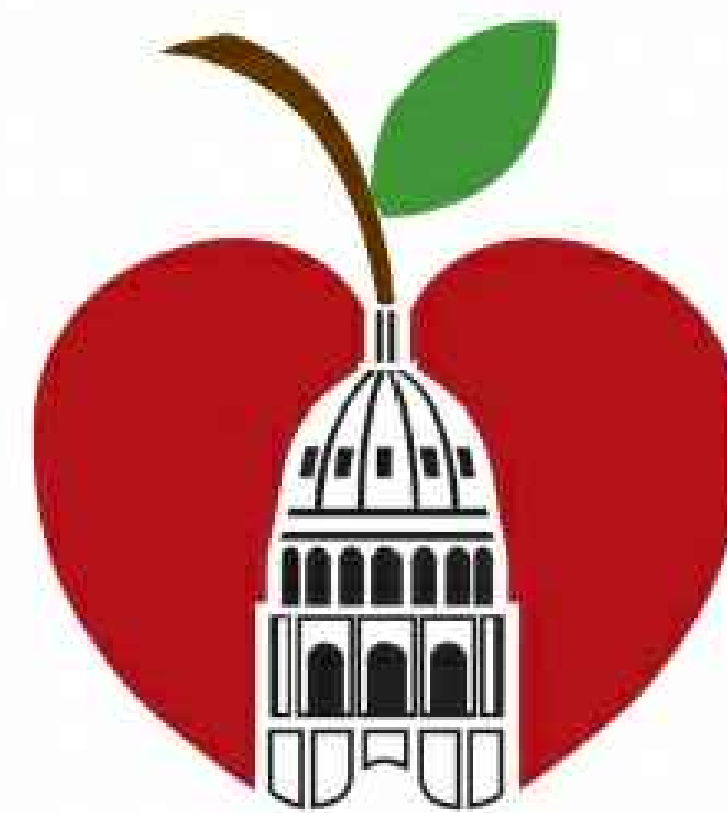

## AISD PROJECT NO. 19-0037-MARTN ROOFING REPAIRS AT MARTIN MIDDLE SCHOOL 1601 HASKELL ST. AUSTIN, TX 78702

### LIST OF MEMBERS OF BOARD OF TRUSTEES

GERONIMO M. RODRIGUEZ, JR., DISTRICT 6, PRESIDENT  
 CINDY ANDERSON, AT-LARGE POSITION 8, VICE PRESIDENT  
 AMBER ELENZ, DISTRICT 5, SECRETARY  
 LATISHA ANDERSON, DISTRICT 1  
 JAYME MATHIAS, DISTRICT 2  
 ANN TEICH, DISTRICT 3  
 YASMIN WAGNER, DISTRICT 7  
 ARATI SINGH, POSITION 9

STEPHANIE S. ELIZALDE, SUPERINTENDENT

#### SITE LOCATOR LEGEND

SYMBOL	DESCRIPTION
	MARTIN MIDDLE SCHOOL 1601 HASKELL ST. AUSTIN, TX 78702

#### SHEET INDEX

SHT. NO.	DESCRIPTION
R0	COVER SHEET
R1	ROOF SCOPE, WARRANTY PLANS, NOTES, SCHEDULES, AND LEGENDS
R2	PARTIAL ROOF PLAN
R3	ROOFING DETAILS
R4	ROOFING DETAILS
R5	ROOFING DETAILS

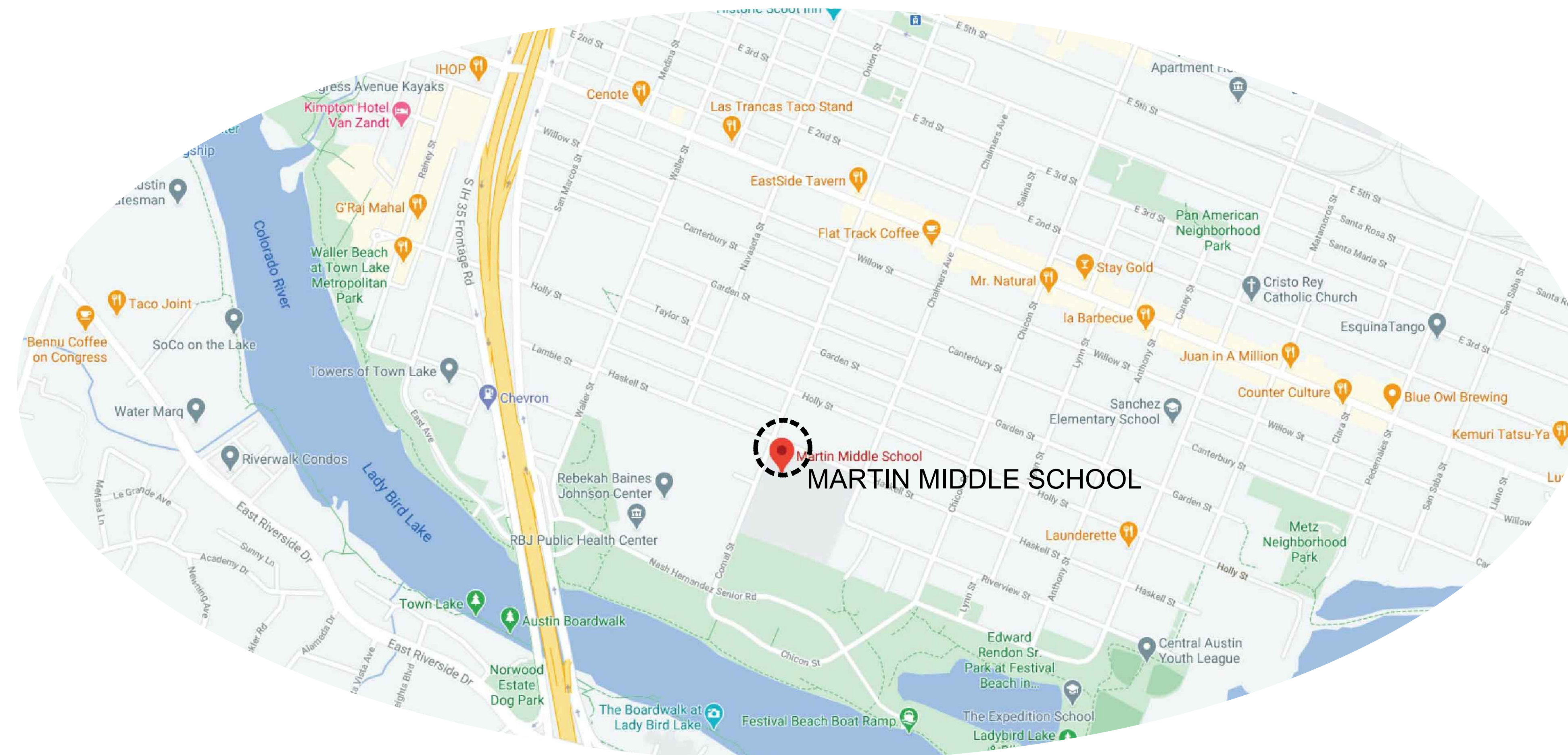

SITE MAP - MARTIN MIDDLE SCHOOL  
NOT TO SCALE  
PLAN NORTH

h  
g  
hollon  
+cannon  
group, inc.  
11800 Highland Oaks Trl, Austin, TX 78750  
P: 512.300.0452  
www.hollon-cannon.com



COVER SHEET
DRAWN BY: MIWH
CHECKED BY: CANNON J
DATE: 10/01/2020
SHEET:

R0

SET NO. \_\_\_\_\_

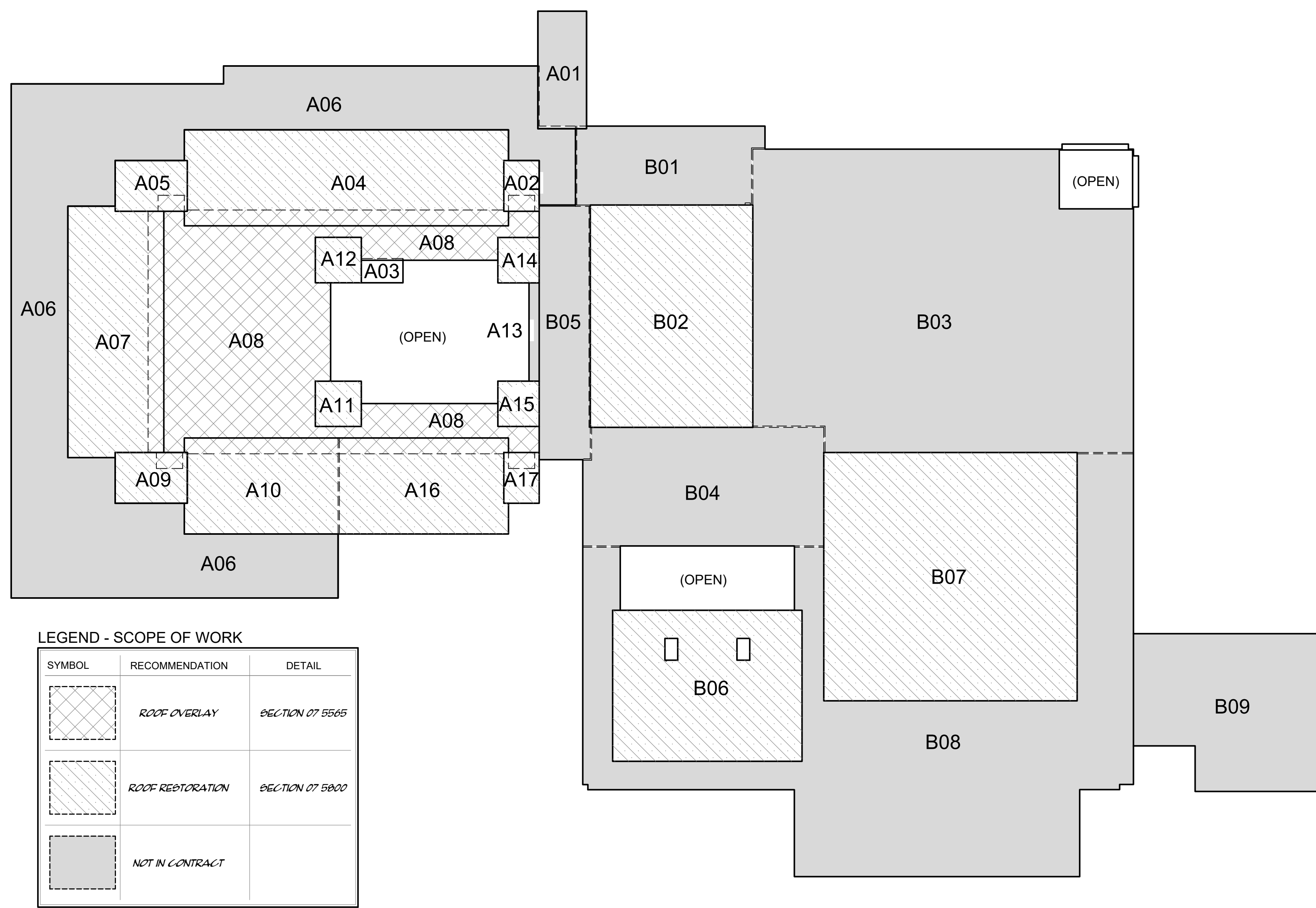

**LEGEND - SCOPE OF WORK**

SYMBOL	RECOMMENDATION	DETAIL
	ROOF OVERLAY	SECTION 07 5505
	ROOF RESTORATION	SECTION 07 5900
	NOT IN CONTRACT	

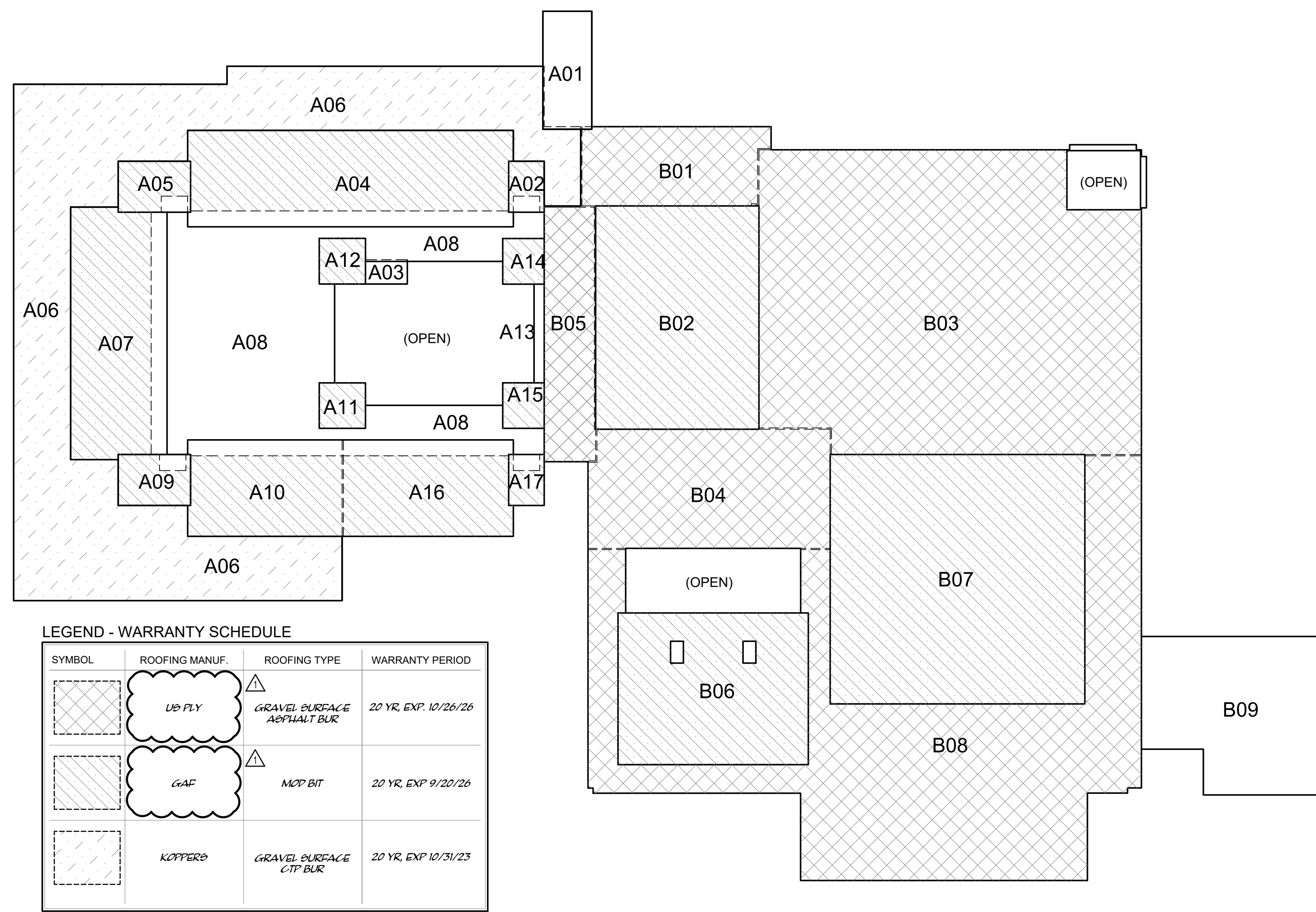

**LEGEND - WARRANTY SCHEDULE**

SYMBOL	ROOFING MANUF.	ROOFING TYPE	WARRANTY PERIOD
	US FLY	GRAVEL SURFACE ASPHALT BUR	20 YR. EXP. 10/26/26
	GAC	MGP BIT	20 YR. EXP. 9/20/26
	KOPPERD	GRAVEL SURFACE CTP BUR	20 YR. EXP. 10/31/23

**1 ROOF SCOPE PLAN - MARTIN HIGH SCHOOL**  
 SCALE: 1" = 30'-0"  
 PLAN NORTH

**2 ROOF WARRANTY PLAN - MARTIN HIGH SCHOOL**  
 SCALE: 1" = 30'-0"  
 PLAN NORTH

**GENERAL NOTES TO CONTRACTORS**

- GENERAL NOTES:**
- CONTRACTOR SHALL VERIFY FIELD DIMENSIONS.
  - FIELD MEASUREMENTS ARE REQUIRED FOR BIDDING PURPOSES.
  - REMOVE BITUMEN PRYOFF FROM MASONRY WALL SURFACES BELOW AWAITED ROOFING SECTIONS.
  - THE REPLACEMENT OF THE ROOF SHALL BE CONDUCTED IN SUCH A MANNER TO PROTECT THE EXISTING BUILDING AND ALL ITS CONTENTS IN THEIR ENTIRETY. THE CONTRACTOR SHALL BE RESPONSIBLE FOR ANY DAMAGE CAUSED BY THE PERFORMANCE OF THEIR WORK.
  - LOCATIONS OF NEW ROOFING AND CRACKETS ARE SHOWN FOR DESIGN INTENT ONLY. THE CONTRACTOR SHALL BE RESPONSIBLE FOR VERIFYING THE PRECISE LOCATION AND PROVIDE THESE ELEMENTS AS REQUIRED FOR A PROPERLY SLOPED AND WATER TIGHT ROOFING SYSTEM.
  - FIELD VERIFY SIZE AND LOCATION OF ALL EXISTING MECHANICAL UNITS, ROOF CURBS, EXHAUSTS AND EXHAUSTS AS WELL AS ANY AND ALL OTHER PENETRATIONS OR ROOF ACCESSORIES AND INSTALL NEW ROOF AS REQUIRED TO ACCOMMODATE ACCESSORIES AND CREATE A WATER TIGHT ROOFING SYSTEM.
- DRAINAGE:**
- CRACKETS / BATTLES SHALL BE TWICE THE ADJACENT ROOF SLOPE.
  - PROVIDE TAPERED CRACKETS ON HIGH SIDE OF CURBED PENETRATIONS AS REQ'D TO PREVENT DRAINAGE AROUND PENETRATION.
  - CONTRACTOR SHALL FIELD VERIFY EXACT EXHAUST SIZE AND PROFILE IN THE FIELD TO ENSURE POSITIVE DRAINAGE AROUND CURBED PENETRATIONS.
  - PROVIDE DOWNSPOUTS WHERE SHOWN ON PLAN, AND AT LOCATIONS TO MATCH EXISTING WHETHER SHOWN ON THE PLAN OR NOT.
  - ALL ROOF DRAINS SHALL BE TESTED FOR A PERIOD OF ONE HOUR FOLLOWING COMPLETION OF THE WORK AND PRIOR TO SUBSTANTIAL COMPLETION. FINAL TESTING WILL OCCUR ONLY IN THE PRESENCE OF THE OWNER'S REPRESENTATIVE. IT IS THE SOLE RESPONSIBILITY OF THE CONTRACTOR TO SCHEDULE AND CONDUCT THE TESTING.
- ROOF TOP EQUIPMENT / PENETRATIONS:**
- CONTRACTOR SHALL VERIFY OPERATIONAL STATUS OF ROOF TOP EQUIPMENT W/ OWNER PRIOR TO COMMENCING WITH THE WORK.
  - ABANDONED EQUIPMENT AND CURBS SHALL BE REMOVED FROM THE BUILDING, AND REPAIRED OR REPAIR FLASHING AT ABANDONED PENETRATIONS (NOT SCHEDULED ON THE DRAWINGS FOR REMOVAL) PER UNIT FLASHING, DETAILS AND SPECIFICATIONS.
  - EXISTING GAB, CONDENSATE, ELECTRICAL, HYDROIC, PIPING, ETC. SHALL BE DISCONNECTED, RAISED AND RECONNECTED AS REQ'D TO ACCOMMODATE NEW ROOF SYSTEM THICKNESS AND MEMBRANE FLASHING HEIGHT REQUIREMENTS.
  - EXISTING ROOF TOP EQUIPMENT SHALL BE DISCONNECTED, RAISED AND RECONNECTED AS REQ'D TO PROVIDE MEMBRANE BANDING FLASHING HEIGHTS SPECIFIED.
  - EXISTING PUCT WORK SHALL BE DISCONNECTED AND RECONNECTED AS REQ'D TO ACCOMMODATE NEW ROOF SYSTEM THICKNESS AND MEMBRANE FLASHING HEIGHT REQUIREMENTS.
  - COORDINATION OF EXISTING BUILDING UTILITIES IS THE RESPONSIBILITY OF THE CONTRACTOR PRIOR TO COMMENCEMENT OF WORK. IF ANY SERVICE TO THE EXISTING SCHOOL IS REQUIRED TO BE SHUT OFF BY THE CONTRACTOR, THE SHUT-OFF MUST BE SCHEDULED IN ADVANCE WITH THE OWNER'S REPRESENTATIVE.
- EQUIPMENT / PIPING SUPPORTS:**
- APPROPRIATE PIPE SUPPORTS ARE DETERMINED BY OUTSIDE DIAMETER OF PIPING / CONDUIT. SEE SPECIFICATION SECTION 07 7200 FOR DESCRIPTIONS OF DESIGNER ROOF TOP PIPE SUPPORTS.
    - a) TYPE "A" - FIXED HEIGHT PIPE SUPPORT RE: DETAIL 1/R4
    - b) TYPE "A" - ADJUSTABLE HEIGHT PIPE SUPPORT RE: DETAIL 2/R4
    - c) TYPE "B" - ADJUSTABLE HEIGHT PIPE SUPPORT RE: DETAIL 3/R4
    - d) TYPE "C" - HANGING PIPE SUPPORT RE: DETAIL 4/R4
    - e) TYPE "D" - CURB MOUNTED PIPE SUPPORT RE: DETAIL 5/R4
    - f) TYPE "E" - HANGING PIPE SUPPORT RE: DETAIL 5/R4
  - REMOVE OF EXISTING PIPE SUPPORTS IS PROHIBITED UNLESS OTHERWISE NOTED.
- PAINTING:**
- SCRAPE PRIME AND PAINT GAB LINES
- TRAFFIC PROTECTION:**
- PROVIDE TRAFFIC PROTECTION PAPER AT ROOF ACCESS POINTS AND ON ALL SIDES OF ROOF TOP UNITS AND AS REQUIRED BY THE SPECIFICATIONS.

**SYMBOL LEGEND**

SYMBOL	LABEL	DESCRIPTION	DETAIL
	VTR	PLUMBING VENT	2/R3
	PD	PENETRATION SEAL	1/R3
	V	FLANGED VENT	3/R3
	HD	HOT STACK	4/R3
	RP	PRIMARY ROOF DRAIN	6/R3
	EF	EXHAUST FAN	5/R3
	VT	CURBED VENT	5/R3
		ENCLOSED CURB	8/R3
	RTU	ROOF TOP UNIT	9/R3
	C	CONDENSATE LINE	
	E	ELECTRICAL LINE	SECTION 07 7200
	G	GAB LINE	
		TAPERED INSULATION	
		DRAINAGE SLOPE	
		NOT IN CONTRACT	

**KEYED NOTES TO CONTRACTOR**

- EXISTING PUCT WORK SHALL BE DISCONNECTED, RAISED AND RECONNECTED AS REQUIRED TO ACCOMMODATE NEW ROOF SYSTEM THICKNESS AND MEMBRANE FLASHING HEIGHT REQUIREMENTS. PROVIDE PUCT SUPPORTS PER DETAIL 7/R4 AT LOCATIONS TO MATCH EXISTING.
- EQUIPMENT SUPPORT CURBS PER DETAIL 7/R3
- DUCT PENETRATION FLASHING THROUGH WALL PER DETAIL 7/R5
- RE-ESTABLISH GUY WIRED TO MATCH EXISTING
- ELECTRICAL PENETRATIONS PER DETAIL 6/R4
- REMOVE FLASHING OFFSET BELOW ROOF DRAIN WHERE REQUIRED FOR ACCESS. PROVIDE OFFSET PATCH OF EQUAL THICKNESS PAINT TO MATCH EXISTING FOR SECTION 07 5100
- PIPING / CONDUIT LOWER THAN 4" ABOVE EXISTING ROOF SURFACE SHALL BE DISCONNECTED, RAISED AND RECONNECTED CONFORMING WITH SUPPORTS, FLASHING AND APPLICABLE SPECIFICATIONS. PROVIDE ALL NECESSARY FLASHING TO MATCH EXISTING.

**EXISTING ROOF ASSEMBLY SCHEDULE**

**ROOF SECTIONS: A08**

- LIGHTWEIGHT CONCRETE DECK
- BASE SHEET
- 1" FIBERGLASS INSULATION
- 4-PLY BUILT-UP ROOFING MEMBRANE MOTTED IN ASPHALT
- ASPHALT FLOOR COAT AND GRAVEL

**NEW ROOF ASSEMBLY SCHEDULE**

**ROOF SECTIONS: A08** (ROOF SYSTEM NO. 1) (DETAIL 3/R1)

- EXISTING ROOF SYSTEM TO REMAIN
- ROOF SURFACE SHALL BE CLEANED OF DEBRIS AND LOOSE GRAVEL
- PROVIDE SCAB BLISTER REPAIR / REMOVAL OF DEGRADATED EXISTING MEMBRANE
- 1/2" HIGH DENSITY ISO COVER BOARD - SET IN ADHESIVE
- 80 MIL SINGLE-PLY MEMBRANE - FULLY ADHERED

**ROOF SECTIONS: A02, A04, A05, A07, A09, A10, A11, A12, A14, A15, A16, A17, B02, B06, B07** (ROOF SYSTEM NO. 2) (DETAIL 4/R1)

- EXISTING MOTTED BITUMEN ROOFING SYSTEM TO REMAIN
- PREPARE MEMBRANE SURFACE PER MANUFACTURER'S RECOMMENDATIONS
- ELASTOMERIC COATING

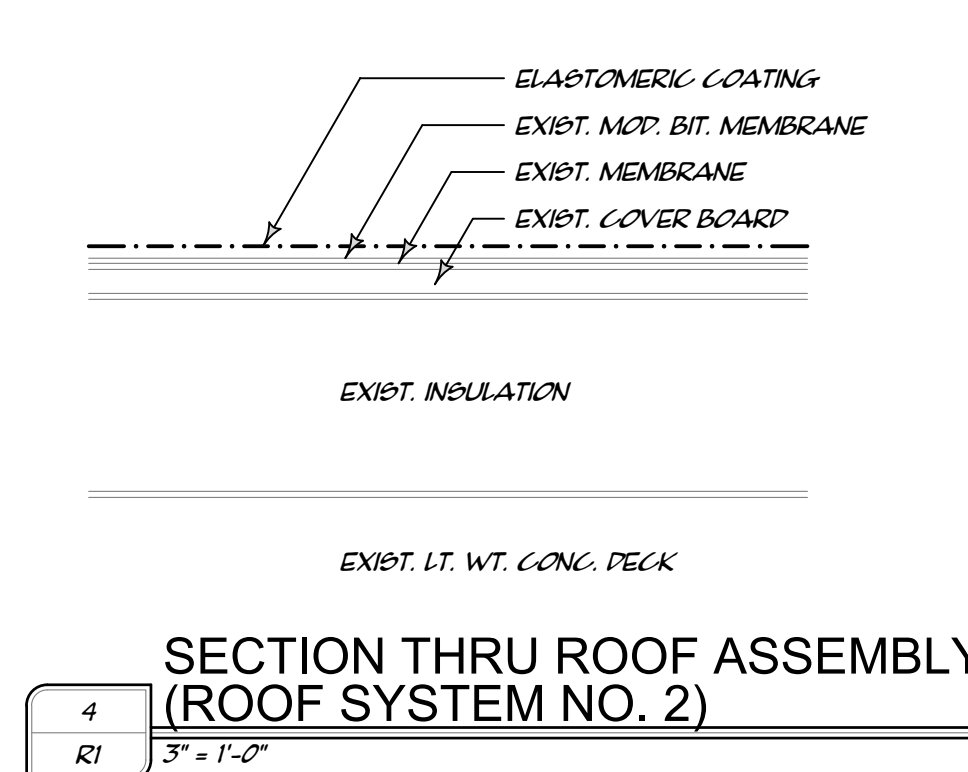
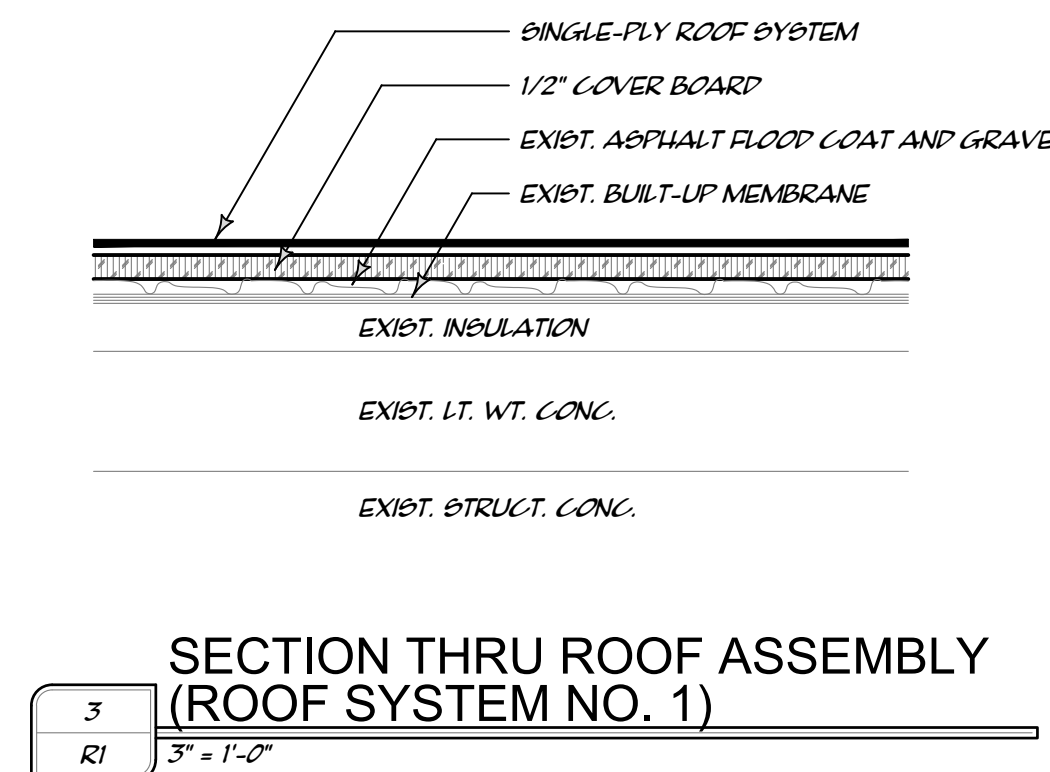

AUSTIN  
 INDEPENDENT SCHOOL DISTRICT  
 ROOFING REPAIRS AT  
 MARTIN MIDDLE SCHOOL  
 PROJECT NO.: 19-0037-MARTIN  
 SOLICITATION NO.: 21CSP034

**REVISION SCHEDULE:**

NO.	ISSUE FOR BID	DATE
1.	ISSUE FOR BID	10/11/20
2.	ADD #2	10/22/20
3.		
4.		
5.		
6.		
7.		



ROOF SCOPE/WARRANTY PLANS, SCHEDULES, AND LEGEND  
 DRAWN BY: MWH  
 CHECKED BY: RR  
 DATE: 10/11/2020  
 SHEET: R1 OF 5

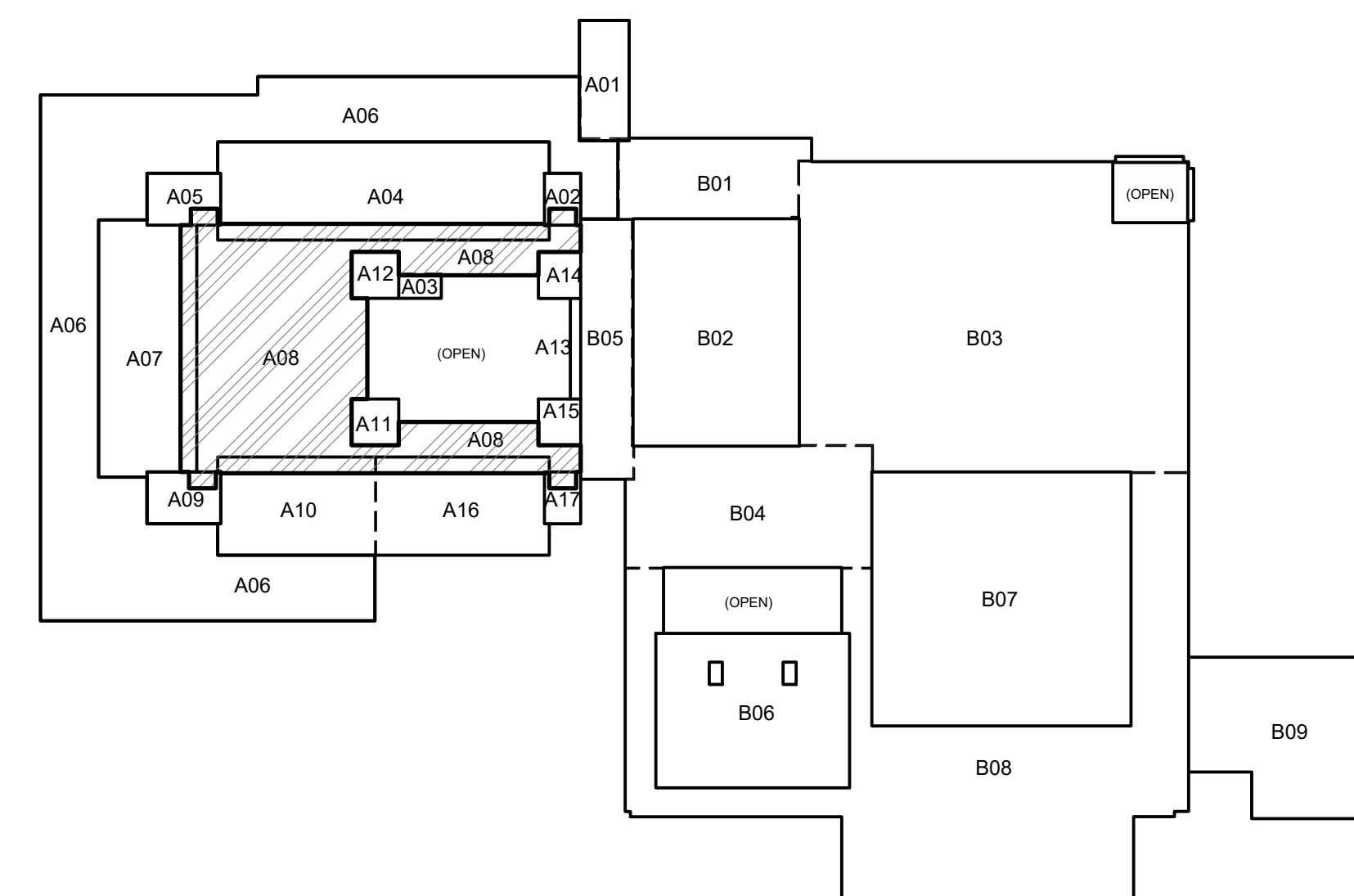
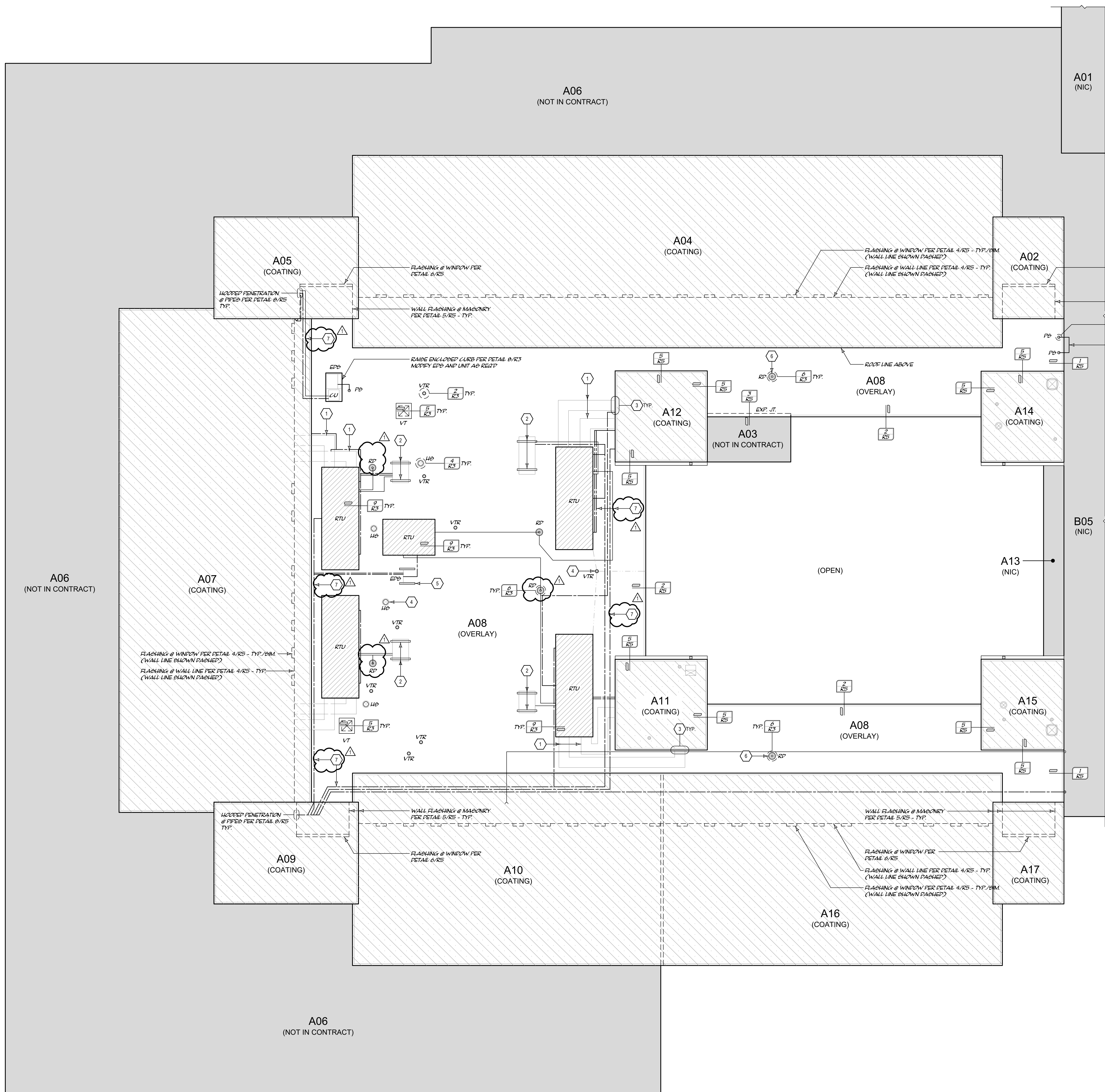

1 PARTIAL ROOF PLAN - MARTIN MIDDLE SCHOOL  
SCALE: 1/8" = 1'-0"  
PLAN NORTH

2 KEY PLAN - MARTIN MIDDLE SCHOOL  
NOT TO SCALE  
PLAN NORTH

REVISION SCHEDULE:

1.	ISSUE FOR BID	10/01/20
2.	ADD #2	10/22/20
3.		
4.		
5.		
6.		
7.		



PARTIAL ROOF PLAN

DRAWN BY: MWH  
 CHECKED BY: RR  
 DATE: 10/11/2020  
 SHEET: R2 OF 5

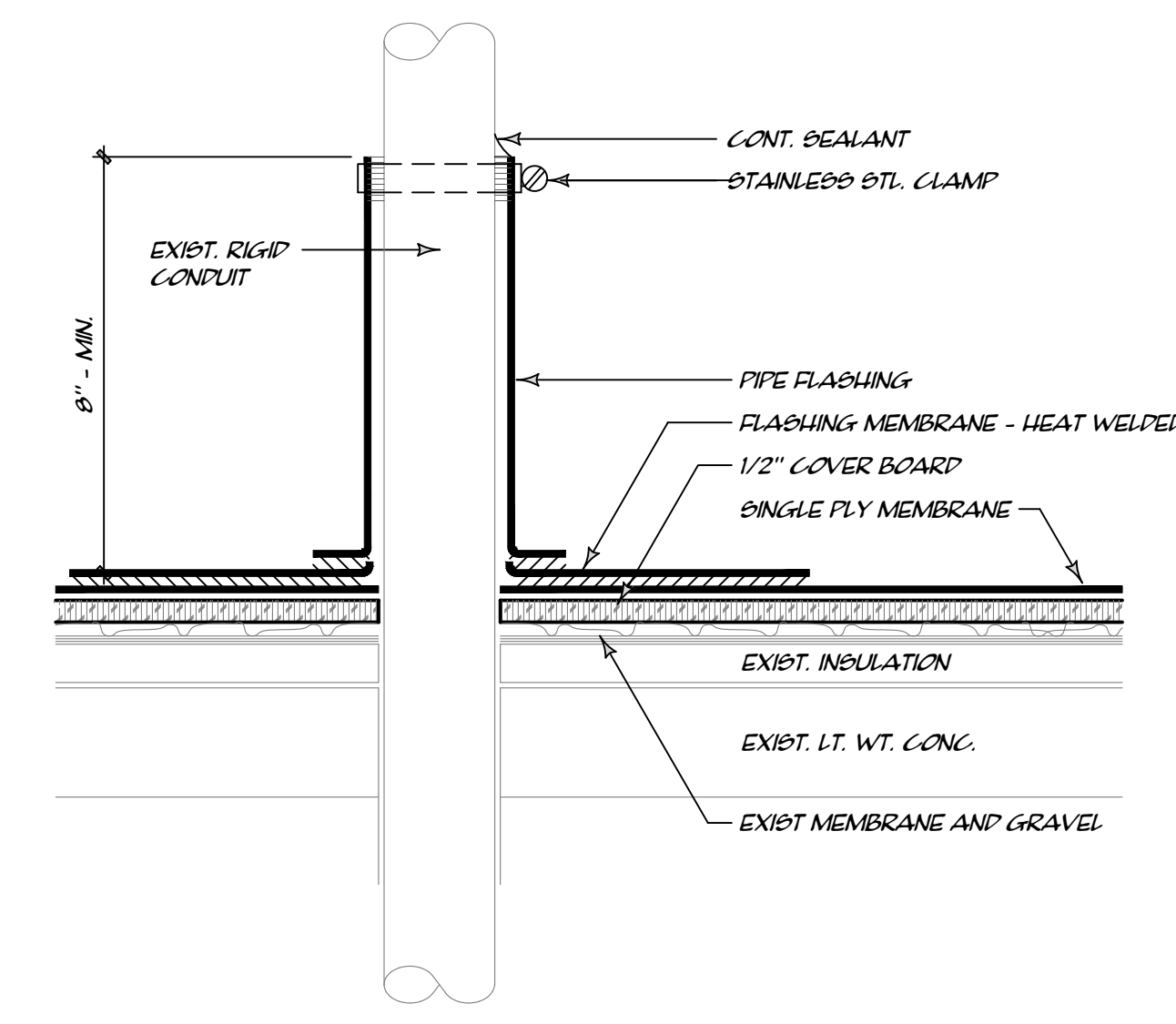

1 PIPE PENETRATION FLASHING  
R3 3\"/>

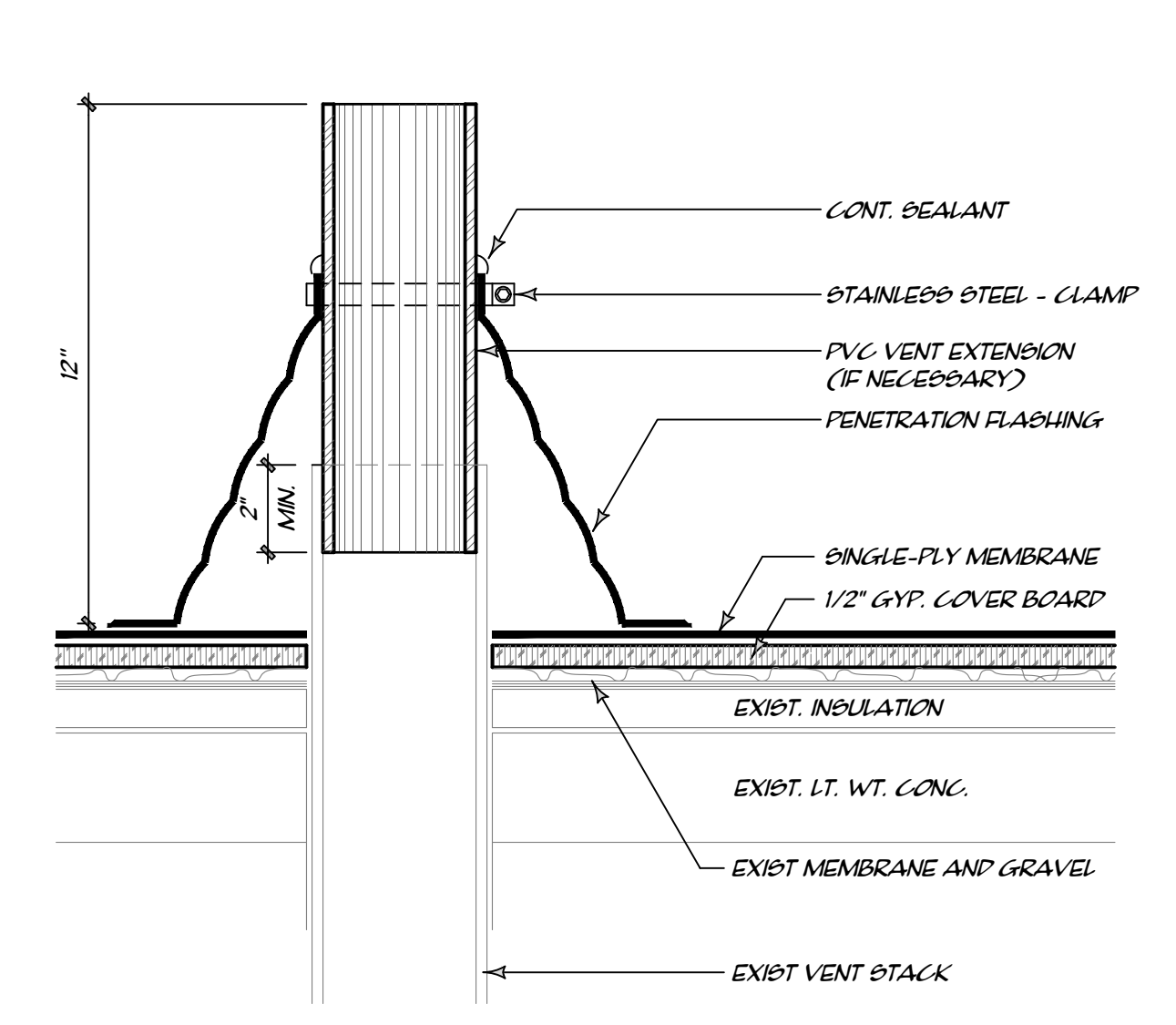

2 VENT THRU ROOF / CONDUIT PENETRATION  
R3 3\"/>

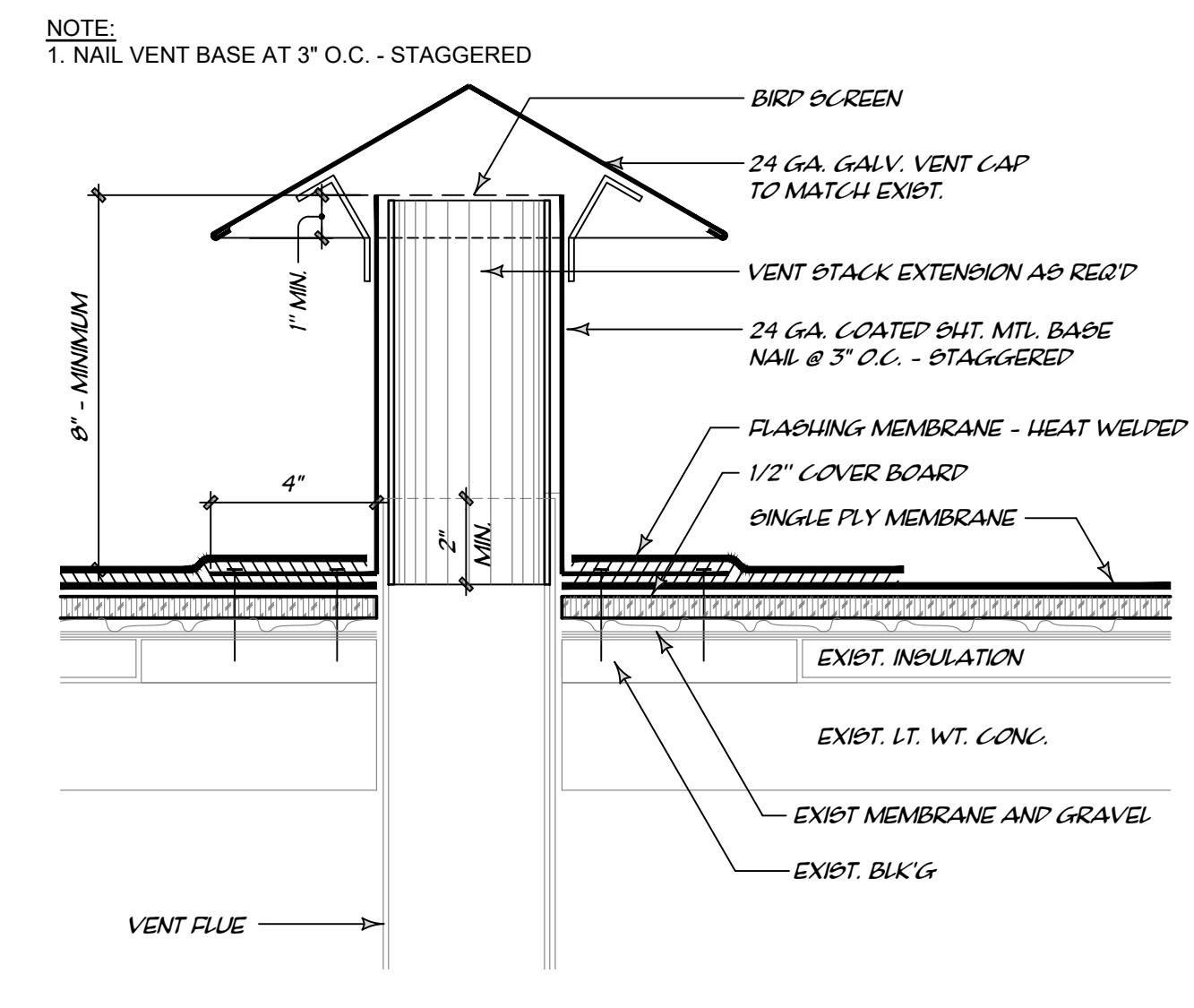

3 FLANGED VENT  
R3 3\"/>

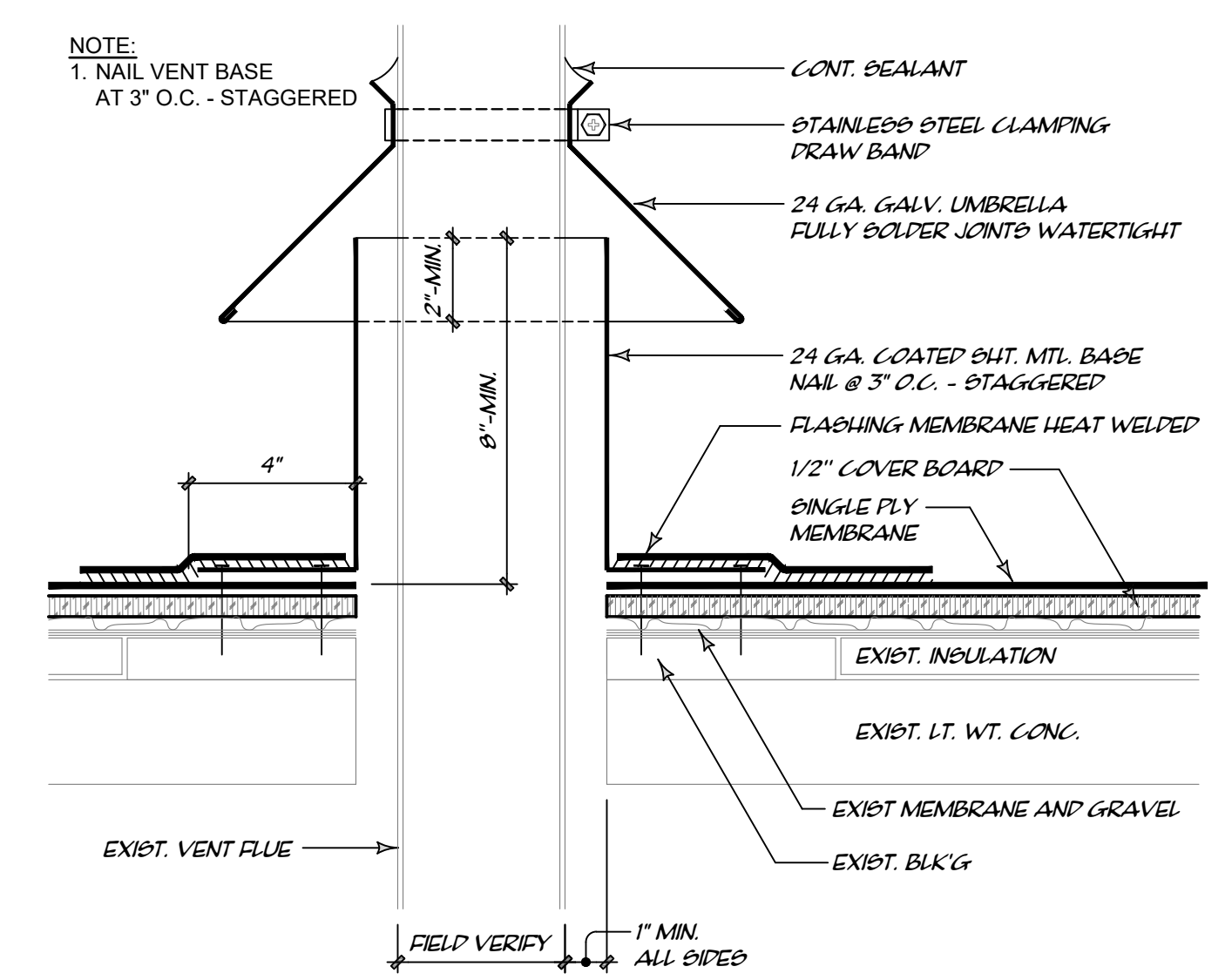

4 HOT STACK  
R3 3\"/>

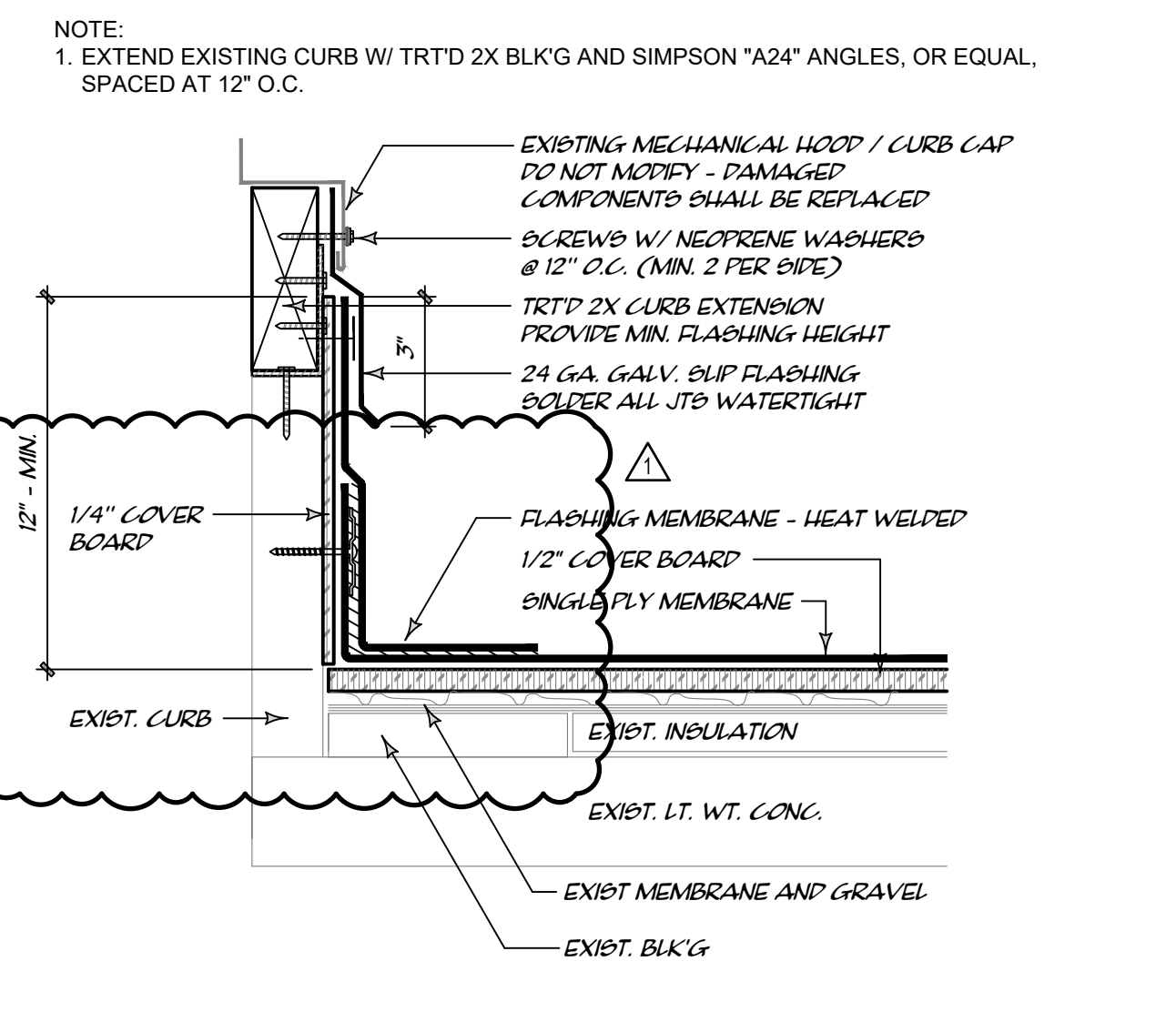

5 MECHANICAL CURB  
R3 3\"/>

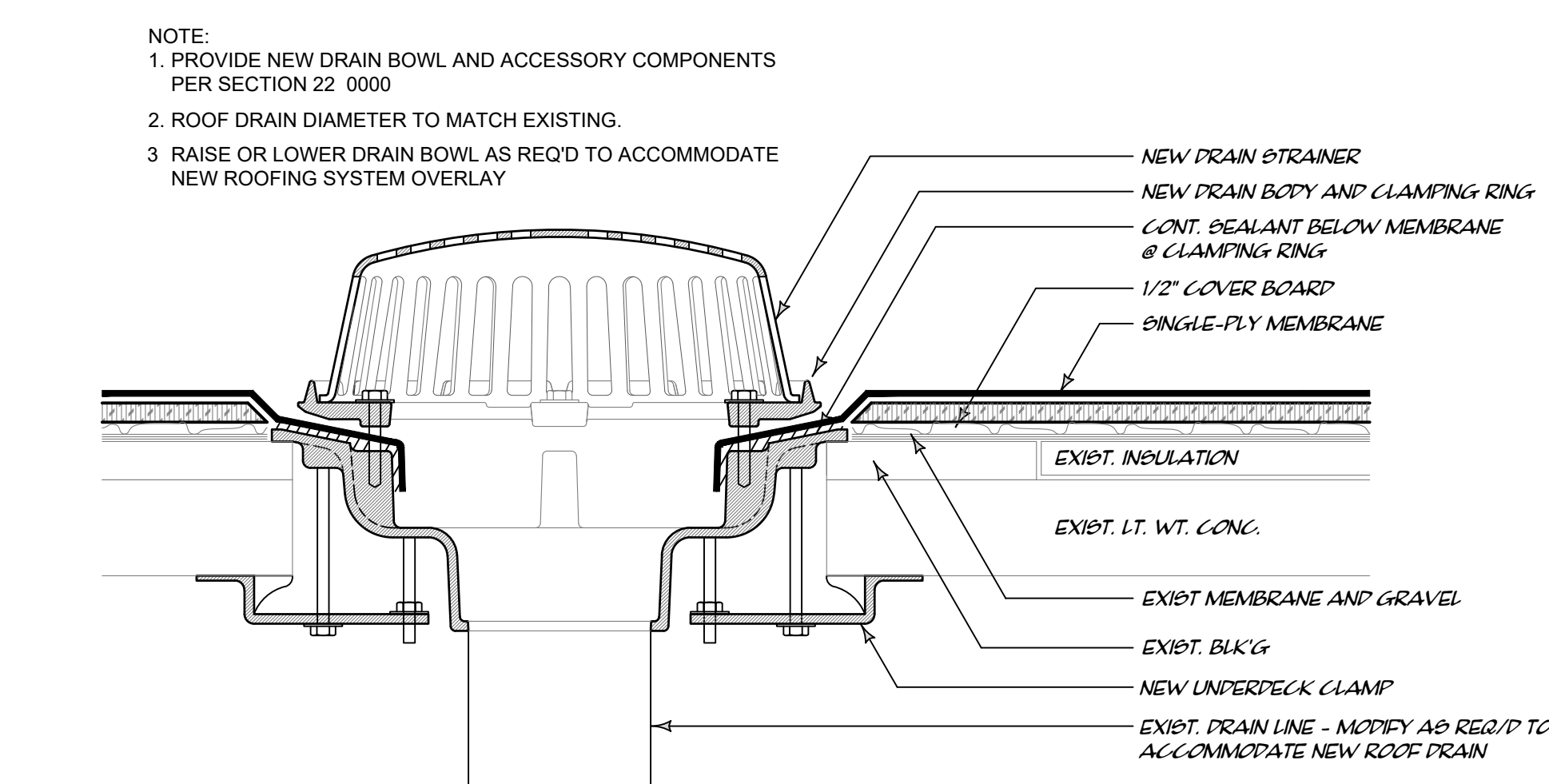

6 ROOF DRAIN (NEW DRAIN BODY / ACCESSORIES)  
R3 3\"/>

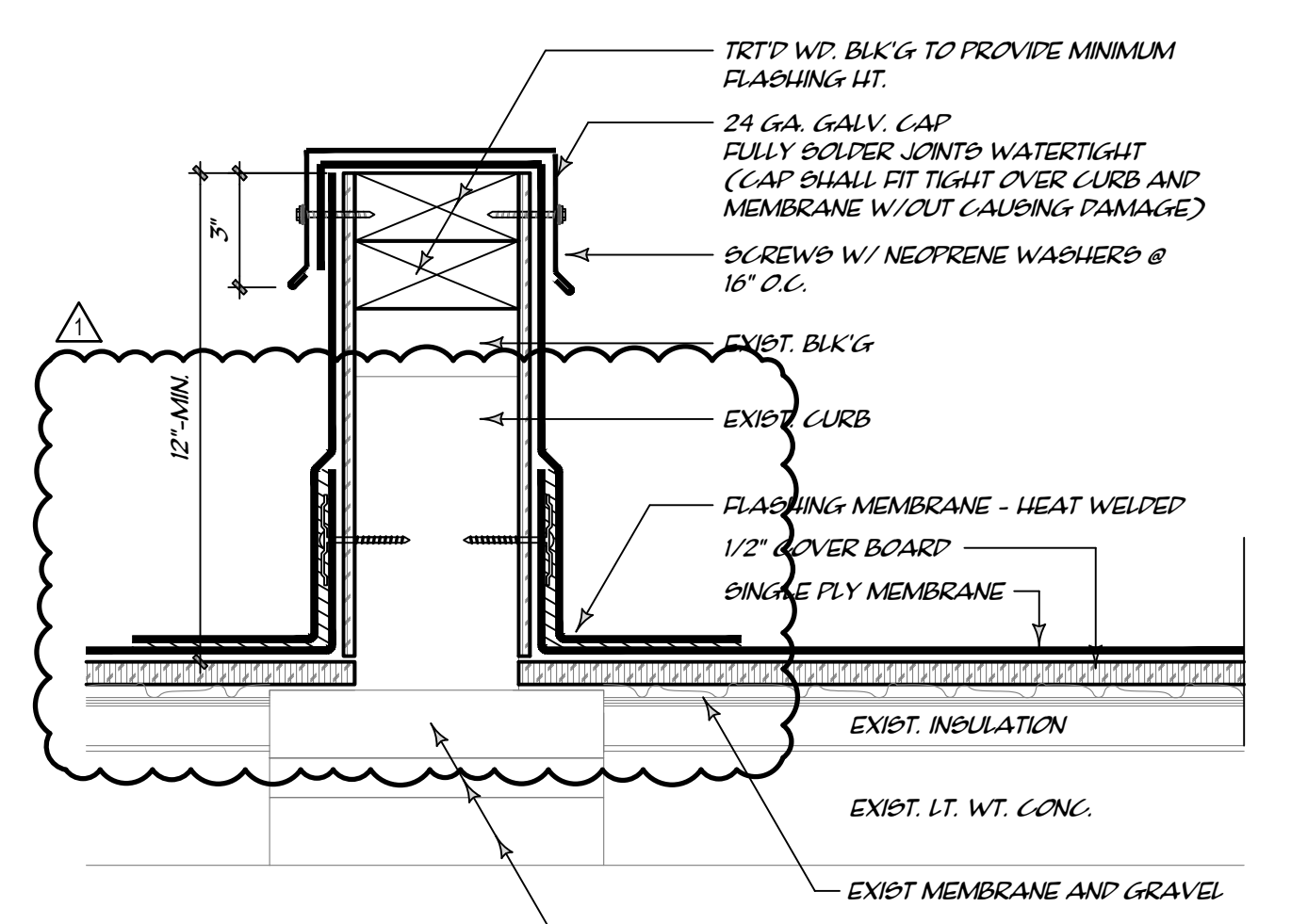

7 EQUIPMENT SUPPORT  
R3 3\"/>

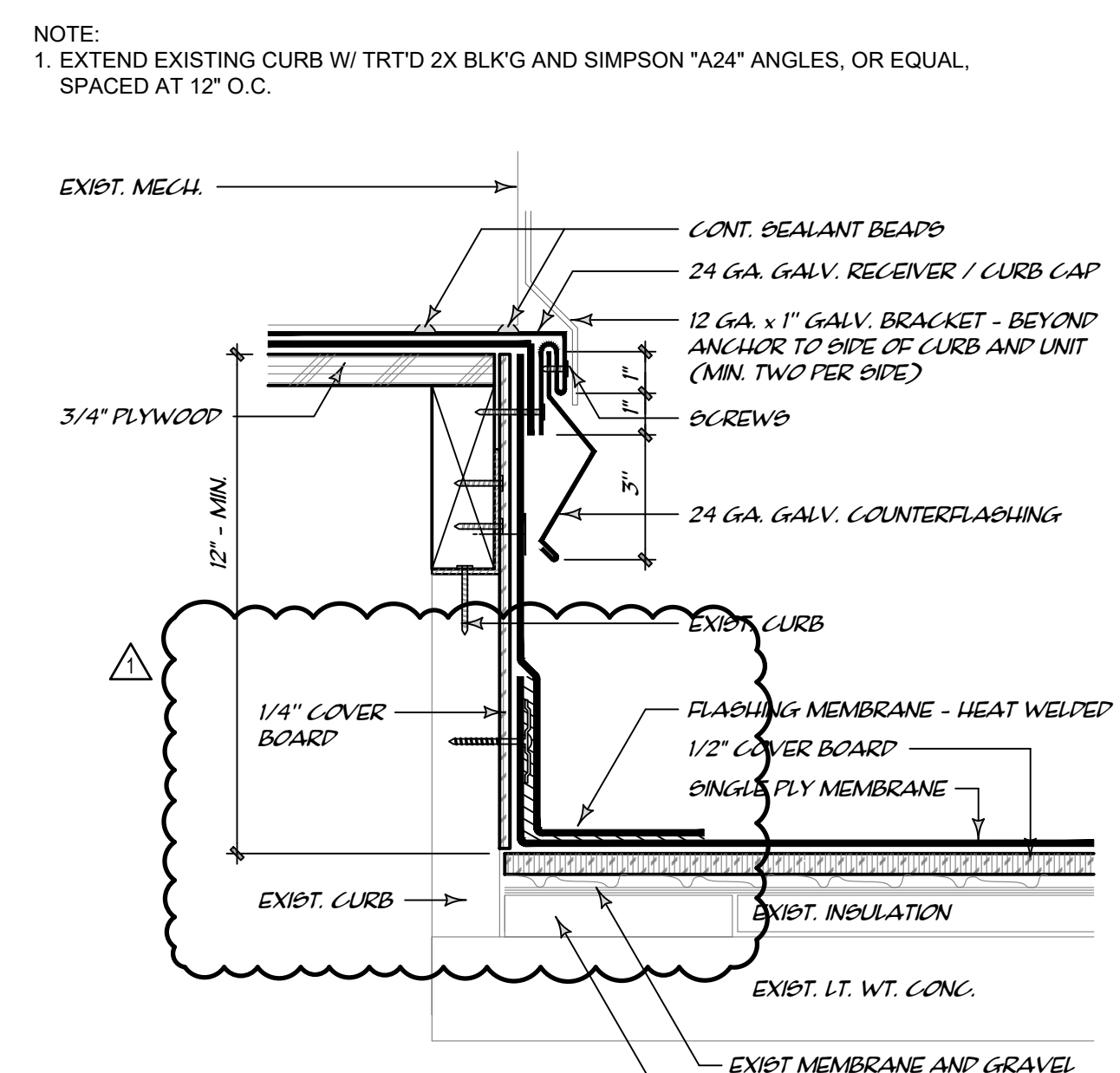

8 ENCLOSED CURB  
R3 3\"/>

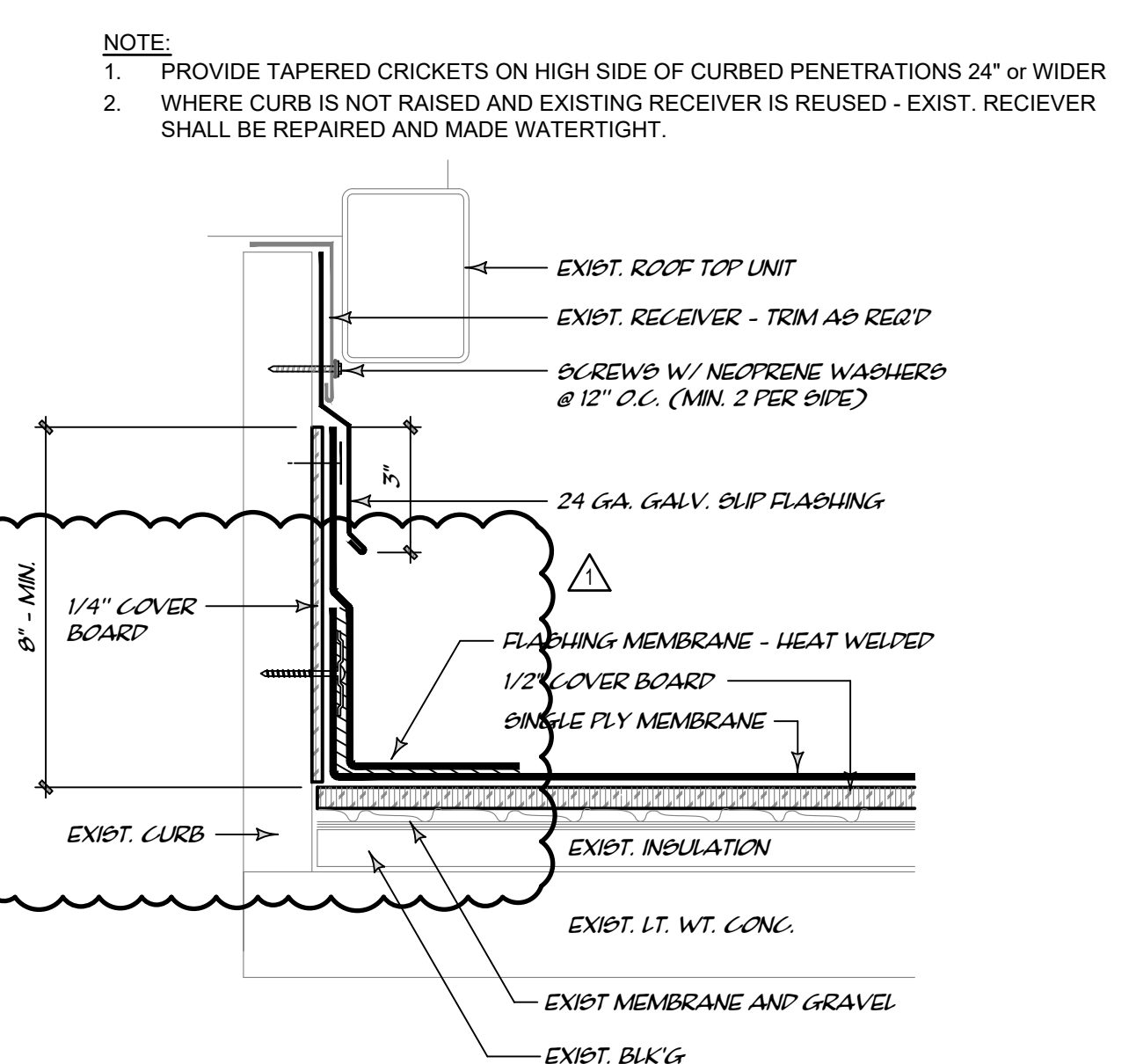

9 HVAC UNIT CURB  
R3 3\"/>

AUSTIN  
INDEPENDENT SCHOOL DISTRICT  
ROOFING REPAIRS AT  
MARTIN MIDDLE SCHOOL  
PROJECT NO.: 19-0037-MARTIN  
SOLICITATION NO.: 21CSP034

REVISION SCHEDULE:	
1.	ISSUE FOR BID 10/11/20
2.	ADD #2 10/22/20
3.	
4.	
5.	
6.	
7.	



ROOFING DETAILS	
DRAWN BY:	MWH
CHECKED BY:	RR
DATE:	10/11/2020
SHEET:	R3 OF 5



- NOTE:  
 1. DISCONNECT, RAISE AND RECONNECT EXISTING CONDENSATE LINES, ETC. AS REQ'D TO ACCOMMODATE HEIGHT OF PIPE SUPPORT.  
 2. SPACE PIPE SUPPORTS @ 8'-0" O.C. MAX.  
 3. PROVIDE PIPE SUPPORTS WITHIN 12'-18" OF CORNERS AND/OR TEE INTERSECTIONS

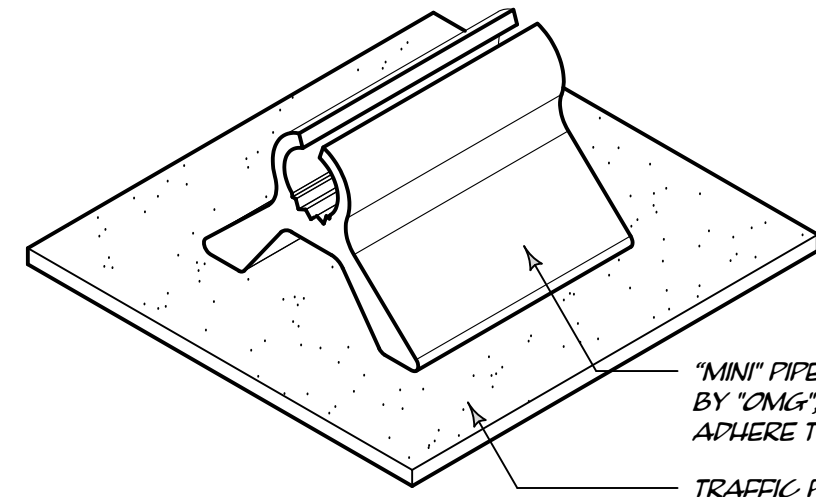

"MINI" PIPE SUPPORT AS MANUFACTURED BY "OMG", OR APPROVED EQUAL. ADHERE TO TRAFFIC PAD W/ SEALANT  
 TRAFFIC PAD 2" LARGER THAN SUPPORT

1 PIPE SUPPORT - FIXED HEIGHT (TYPE "A")  
 R4 NOT TO SCALE

- NOTE:  
 1. DISCONNECT, RAISE AND RECONNECT EXISTING CONDENSATE LINES, ETC. AS REQ'D TO ACCOMMODATE HEIGHT OF PIPE SUPPORT.  
 2. SPACE PIPE SUPPORTS @ 8'-0" O.C. MAX.  
 3. PROVIDE PIPE SUPPORTS WITHIN 12'-18" OF CORNERS AND/OR TEE INTERSECTIONS

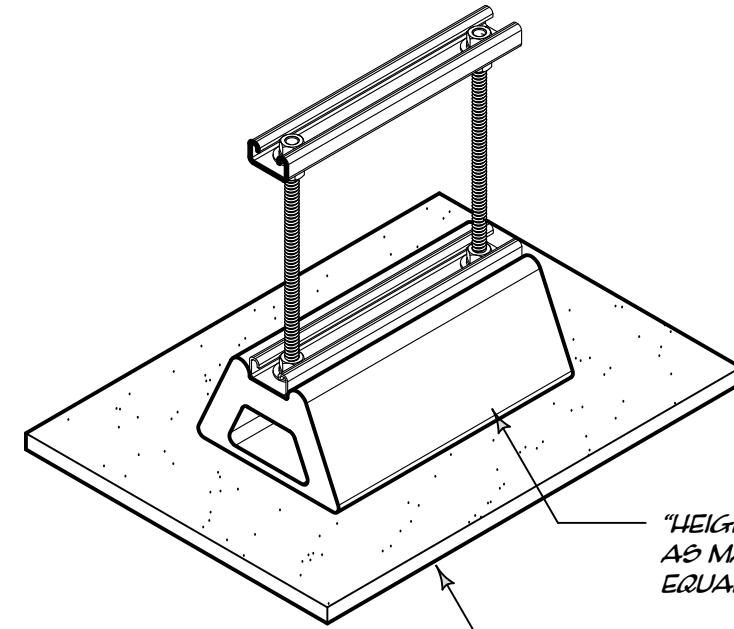

"HEIGHT ADJUSTABLE STRUT ONLY PIPE GUARD" AS MANUFACTURED BY "OMG", OR APPROVED EQUAL. ADHERE TO PROTECTION PAD W/ SEALANT  
 TRAFFIC PAD 2" LARGER THAN SUPPORT

2 PIPE SUPPORT - ADJUSTABLE HEIGHT (TYPE "B")  
 R4 NOT TO SCALE

- NOTE:  
 1. DISCONNECT, RAISE AND RECONNECT EXISTING GAS LINES, ELECTRICAL LINES, ETC. AS REQ'D TO ACCOMMODATE HEIGHT OF PIPE SUPPORT.  
 2. SPACE PIPE SUPPORTS @ 8'-0" O.C. MAX.  
 3. PROVIDE PIPE SUPPORTS WITHIN 12'-18" OF CORNERS AND/OR TEE INTERSECTIONS  
 4. PROVIDE PIPE RETAINER BRACKETS

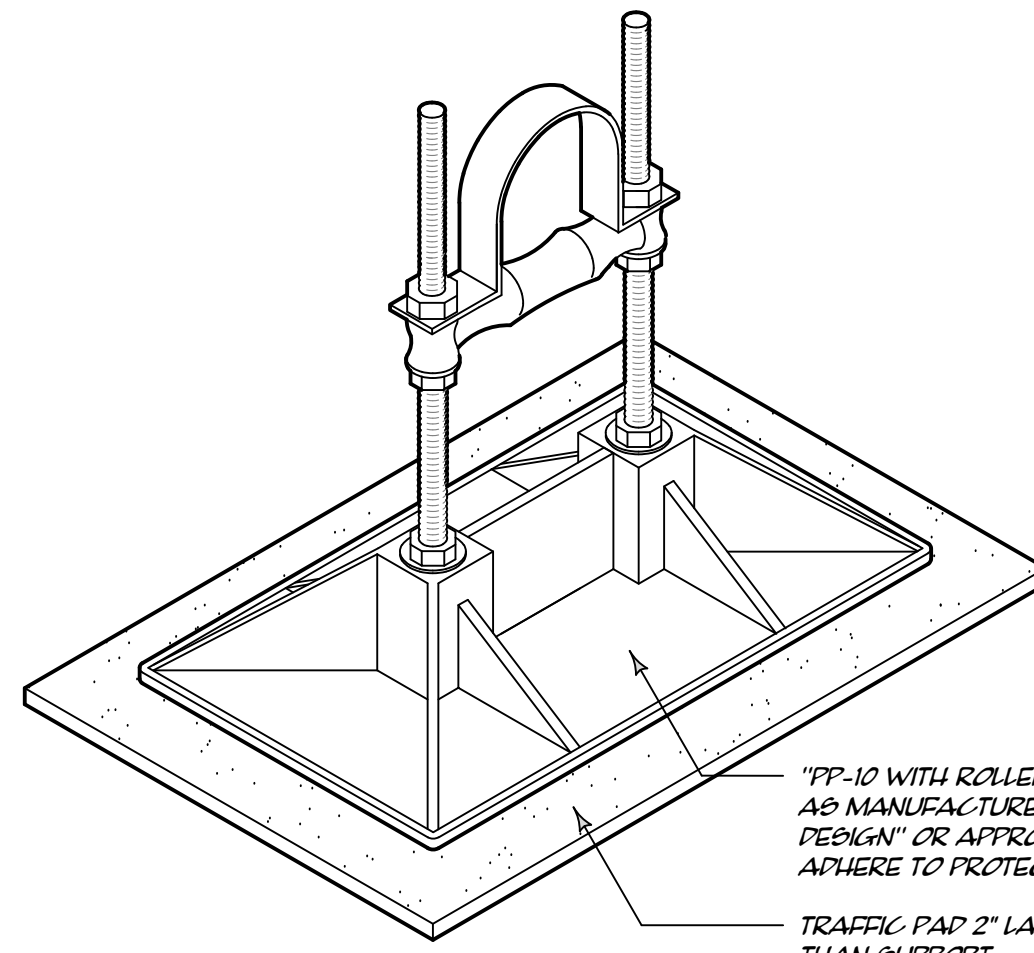

"TP-10 WITH ROLLER" PIPE SUPPORT AS MANUFACTURED BY "TUP SYSTEM / DESIGN" OR APPROVED EQUAL. ADHERE TO PROTECTION PAD W/ SEALANT  
 TRAFFIC PAD 2" LARGER THAN SUPPORT

3 PIPE SUPPORT - ADJUSTABLE HEIGHT (TYPE "B")  
 R4 NOT TO SCALE

- NOTE:  
 1. DISCONNECT, RAISE AND RECONNECT EXISTING GAS LINES, ELECTRICAL LINES, ETC. AS REQ'D TO ACCOMMODATE HEIGHT OF PIPE SUPPORT.  
 2. SPACE PIPE SUPPORTS @ 8'-0" O.C. MAX.  
 3. NUMBER AND SIZE OF PIPES VARIES  
 4. PROVIDE PIPE SUPPORTS WITHIN 12'-18" OF CORNERS AND/OR TEE INTERSECTIONS

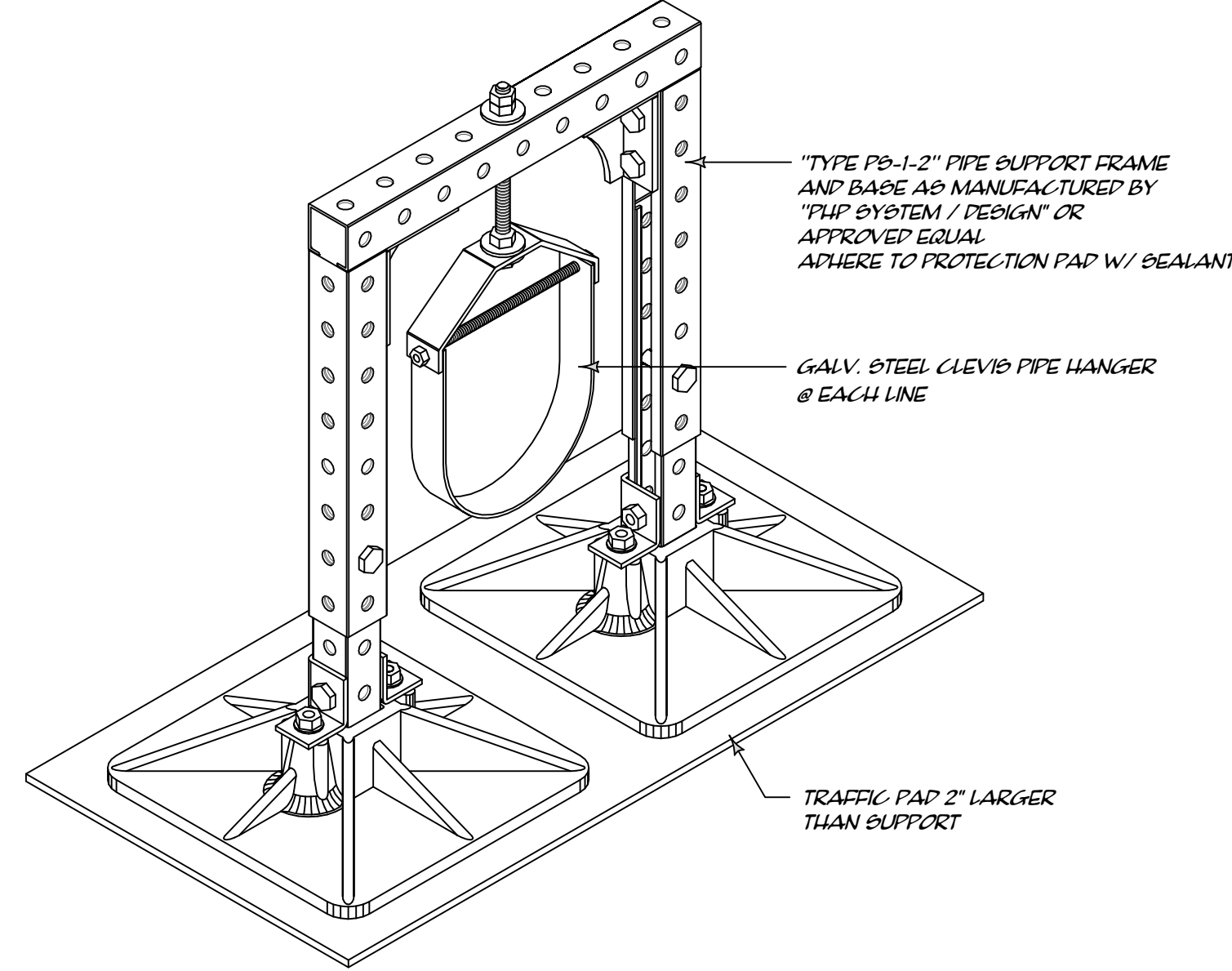

"TYPE PD-1-2" PIPE SUPPORT FRAME AND BASE AS MANUFACTURED BY "TUP SYSTEM / DESIGN" OR APPROVED EQUAL. ADHERE TO PROTECTION PAD W/ SEALANT  
 GALV. STEEL CLEVER PIPE HANGER @ EACH LINE  
 TRAFFIC PAD 2" LARGER THAN SUPPORT

4 HANGING PIPE SUPPORT (TYPE "C")  
 R4 NOT TO SCALE

- NOTE:  
 1. DISCONNECT, RAISE AND RECONNECT EXISTING GAS LINES, ELECTRICAL LINES, ETC. AS REQ'D TO ACCOMMODATE HEIGHT OF NEW CURB AND PIPE ROLLER ASSEMBLY.  
 2. SPACE PIPE SUPPORTS @ 8'-0" O.C. MAX.  
 3. PROVIDE PIPE SUPPORTS WITHIN 12'-18" OF CORNERS AND/OR TEE INTERSECTIONS  
 4. CONTRACTOR MAY REUSE EXISTING ROLLER SUPPORT WHERE IN COMPLIANCE WITH SPECIFICATION SECTION 07 7200 AND APPLICABLE DETAILS

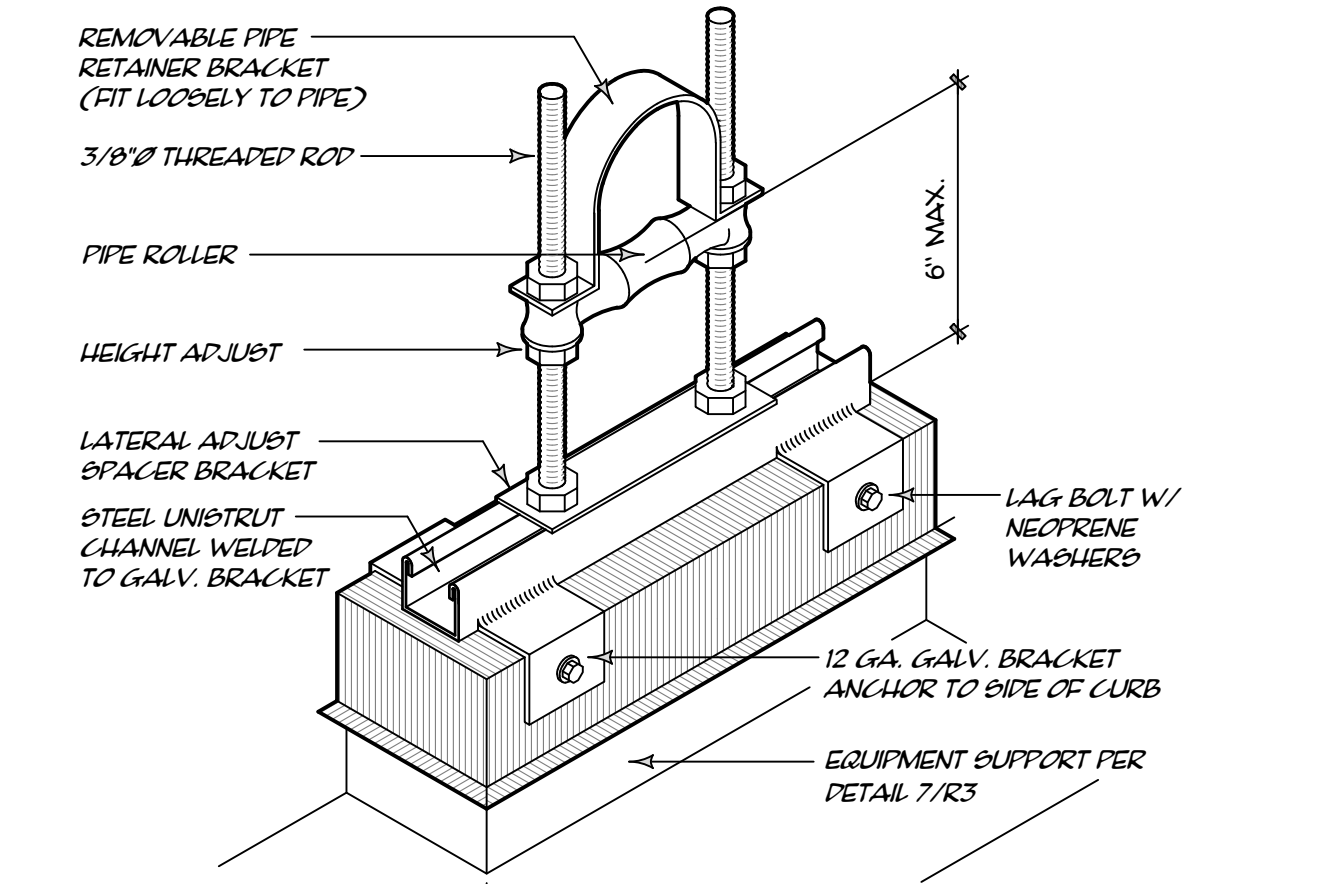

REMOVABLE PIPE RETAINER BRACKET (FIT LOOSELY TO PIPE)  
 3/8" THREADED ROD  
 PIPE ROLLER  
 HEIGHT ADJUST  
 LATERAL ADJUST BRACKET  
 STEEL UNISTRUT CHANNEL WELDED TO GALV. BRACKET  
 LAG BOLT W/ NYLON WASHERS  
 12 GA. GALV. BRACKET ANCHOR TO PIPE OR CURB  
 EQUIPMENT SUPPORT PER DETAIL 7/R3  
 6" MAX.

5 CURB MOUNTED PIPE ROLLER SUPPORT (TYPE "D")  
 R4 NOT TO SCALE

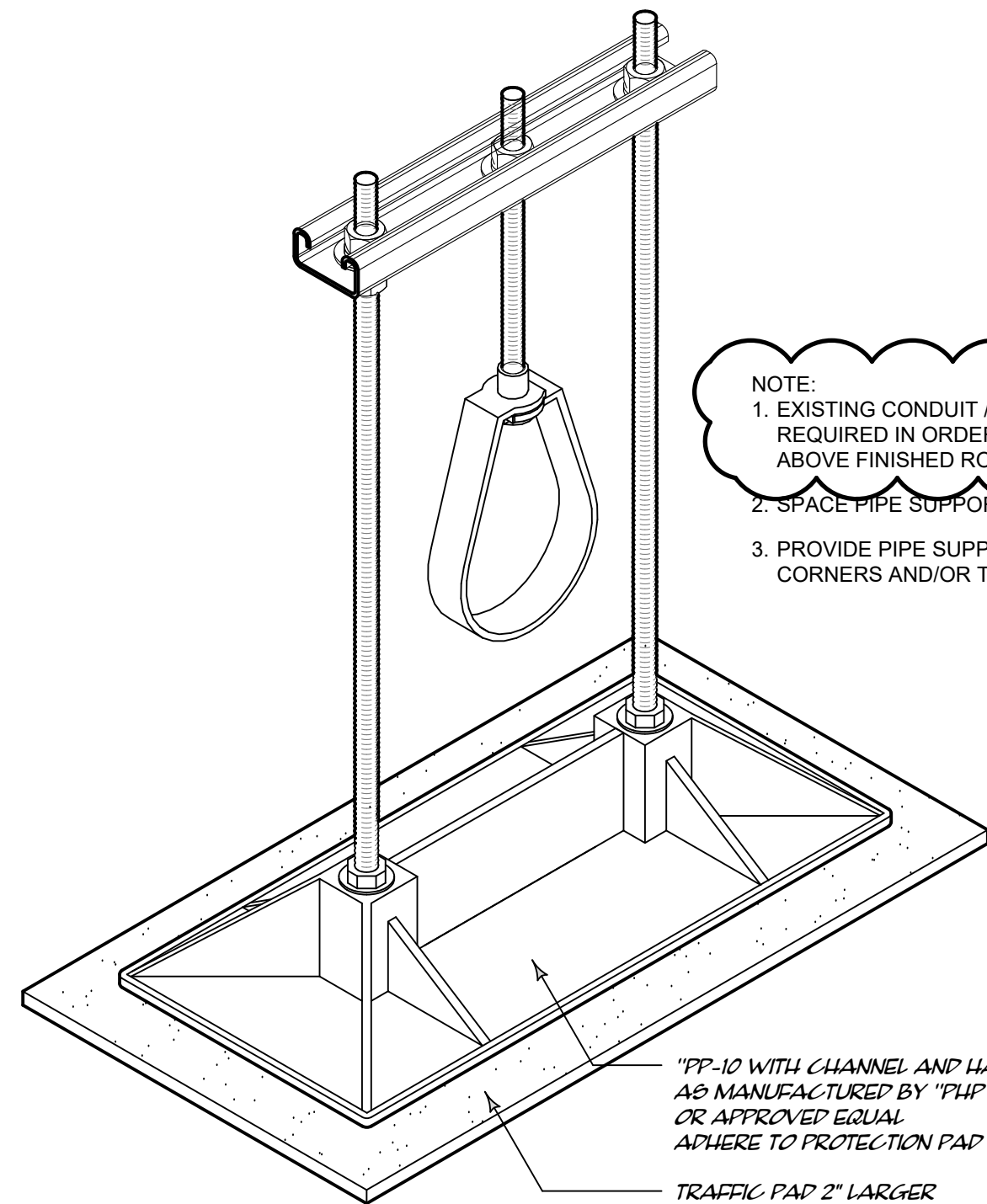

NOTE:  
 1. EXISTING CONDUIT / PIPING SHALL BE RAISED WHERE REQUIRED IN ORDER TO MEET MINIMUM 4" CLEARANCE ABOVE FINISHED ROOF SURFACE  
 2. SPACE PIPE SUPPORTS @ 8'-0" O.C. MAX.  
 3. PROVIDE PIPE SUPPORTS WITHIN 12'-18" OF CORNERS AND/OR TEE INTERSECTIONS

"TP-10 WITH CHANNEL AND HANGER" PIPE SUPPORT AS MANUFACTURED BY "TUP SYSTEM / DESIGN" OR APPROVED EQUAL. ADHERE TO PROTECTION PAD W/ SEALANT  
 TRAFFIC PAD 2" LARGER THAN SUPPORT

A SUPPORT @ SINGLE LINE  
 R4 NOT TO SCALE  
 6 PIPE SUPPORT - ADJUSTABLE HEIGHT (TYPE "E")  
 R4 NOT TO SCALE

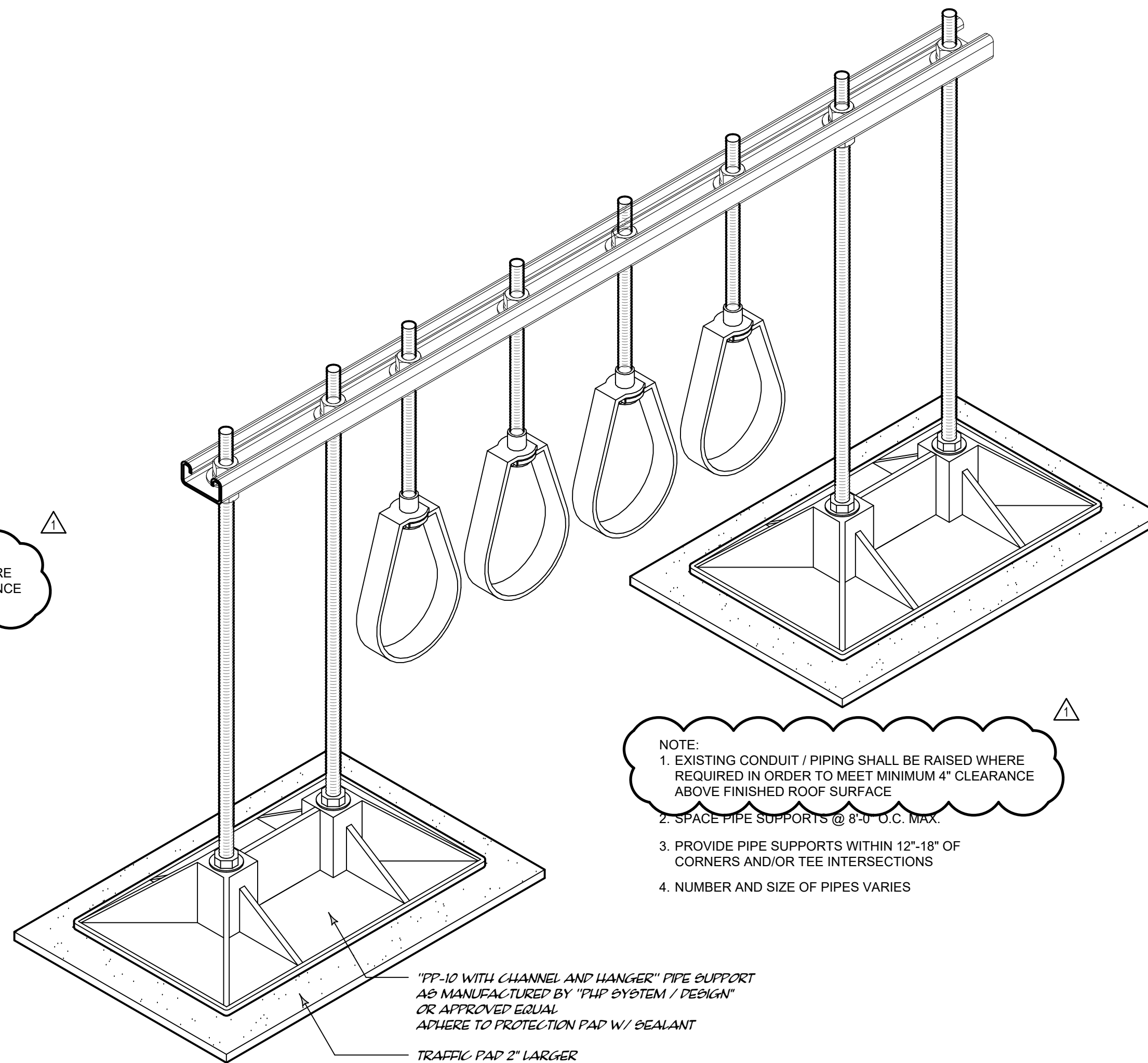

NOTE:  
 1. EXISTING CONDUIT / PIPING SHALL BE RAISED WHERE REQUIRED IN ORDER TO MEET MINIMUM 4" CLEARANCE ABOVE FINISHED ROOF SURFACE  
 2. SPACE PIPE SUPPORTS @ 8'-0" O.C. MAX.  
 3. PROVIDE PIPE SUPPORTS WITHIN 12'-18" OF CORNERS AND/OR TEE INTERSECTIONS  
 4. NUMBER AND SIZE OF PIPES VARIES

"TP-10 WITH CHANNEL AND HANGER" PIPE SUPPORT AS MANUFACTURED BY "TUP SYSTEM / DESIGN" OR APPROVED EQUAL. ADHERE TO PROTECTION PAD W/ SEALANT  
 TRAFFIC PAD 2" LARGER THAN SUPPORT

B SUPPORT @ MULTIPLE LINES  
 R4 NOT TO SCALE

- NOTE:  
 1. PROVIDE DUCT SUPPORT SYSTEM. VERIFY APPROPRIATE SIZE IN FIELD

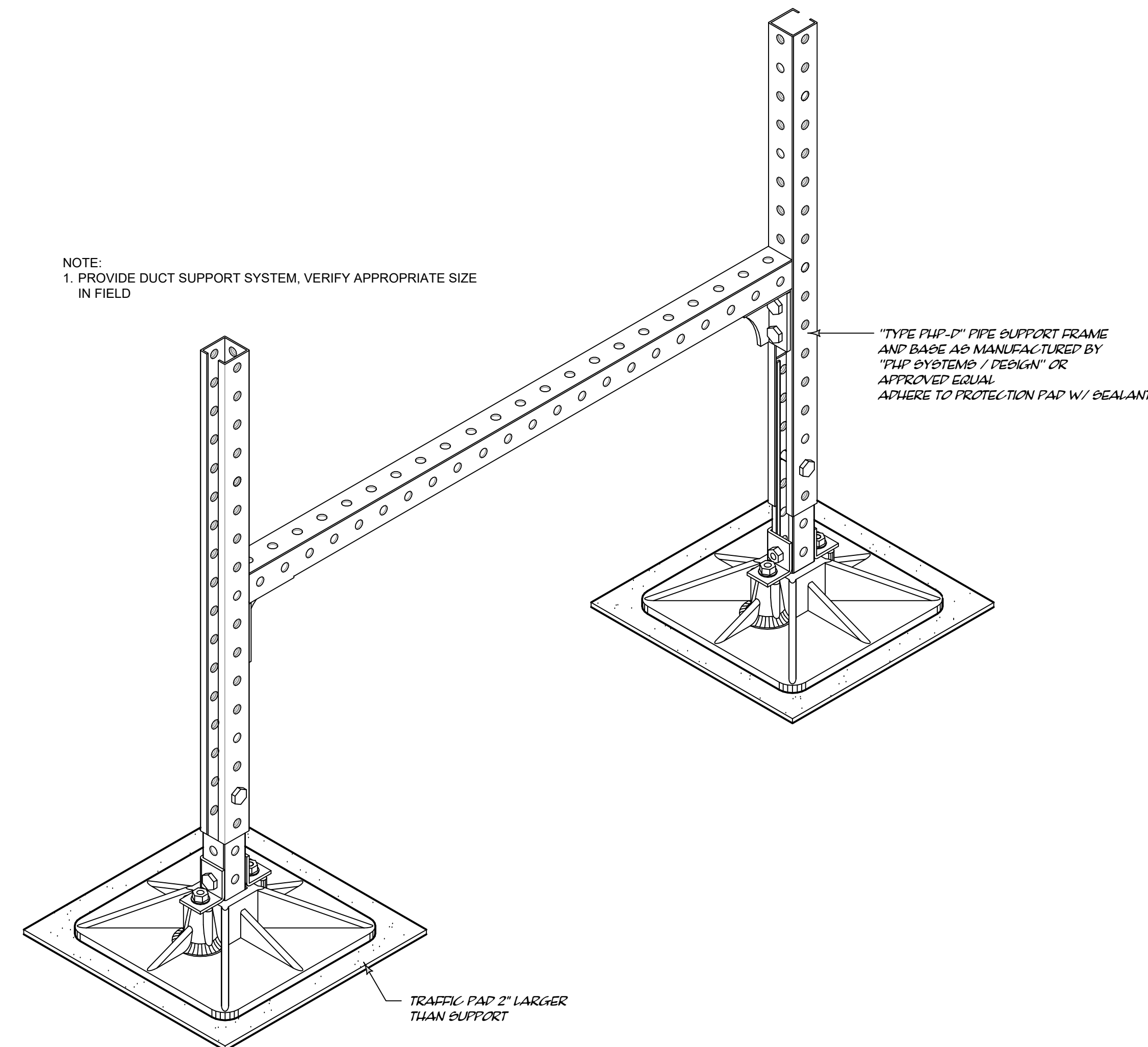

"TYPE PD-0" PIPE SUPPORT FRAME AND BASE AS MANUFACTURED BY "TUP SYSTEM / DESIGN" OR APPROVED EQUAL. ADHERE TO PROTECTION PAD W/ SEALANT  
 TRAFFIC PAD 2" LARGER THAN SUPPORT

7 DUCT SUPPORT  
 R4 NOT TO SCALE

- NOTE:  
 1. CONTRACTOR MAY REUSE EXISTING UNISTRUT RACK WHERE IN COMPLIANCE WITH CONTRACT DOCUMENTS

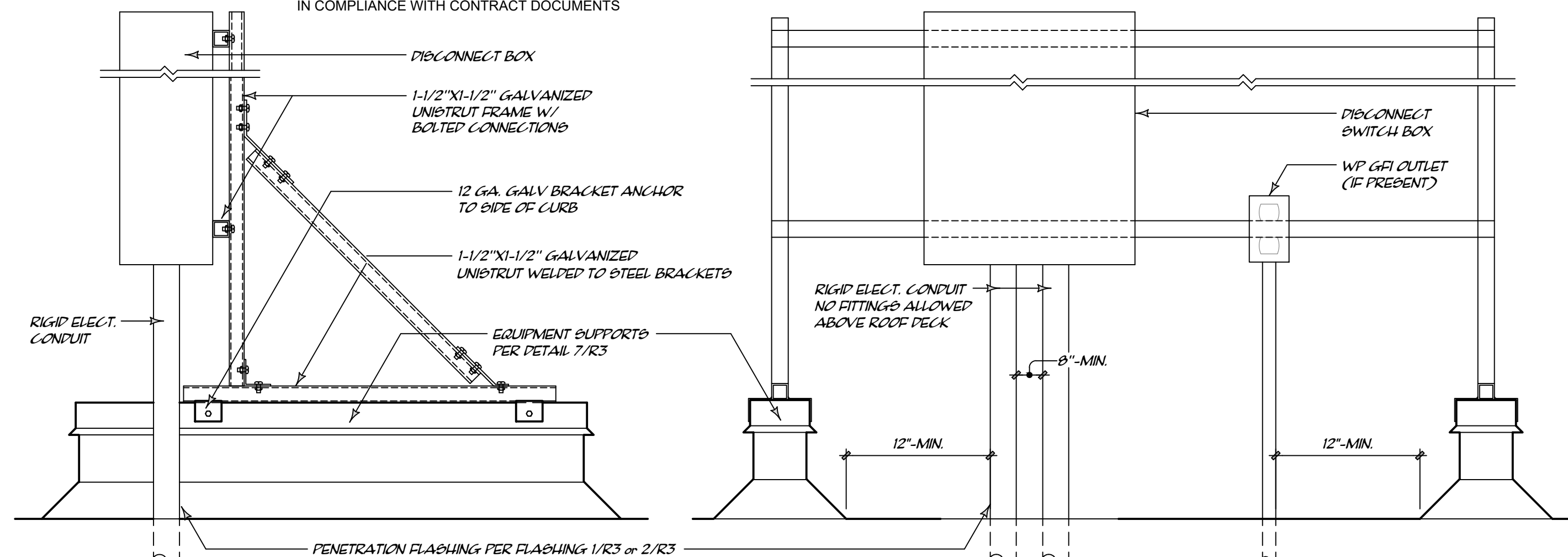

DISCONNECT BOX  
 1-1/2" X 1-1/2" GALVANIZED UNISTRUT FRAME W/ BOLTED CONNECTIONS  
 12 GA. GALV BRACKET ANCHOR TO PIPE OR CURB  
 1-1/2" X 1-1/2" GALVANIZED UNISTRUT WELDED TO STEEL BRACKET  
 EQUIPMENT SUPPORT PER DETAIL 7/R3  
 RIGHT ELECT. CONDUIT  
 PENETRATION FLASHING PER FLASHING 1/R3 or 2/R3  
 DISCONNECT SWITCH BOX  
 WF GR. OUTLET (IF PRESENT)  
 RIGHT ELECT. CONDUIT - NO FITTINGS ALLOWED ABOVE ROOF DECK  
 8" MIN.  
 12" MIN.  
 12" MIN.

8 ELECTRICAL DISCONNECT SUPPORT  
 R4 NOT TO SCALE

REVISION SCHEDULE:	
1.	ISSUE FOR BID 10/01/20
2.	ADD #2 10/22/20
3.	
4.	
5.	
6.	
7.	

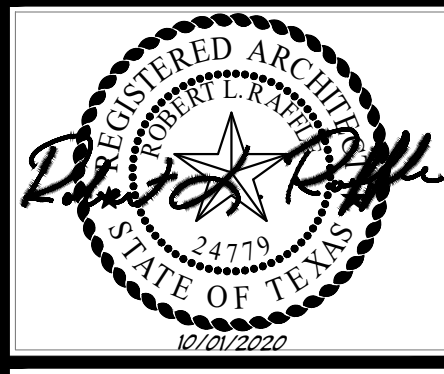

ROOFING DETAILS	
DRAWN BY:	MWH
CHECKED BY:	RR
DATE:	10/11/2020
SHEET:	

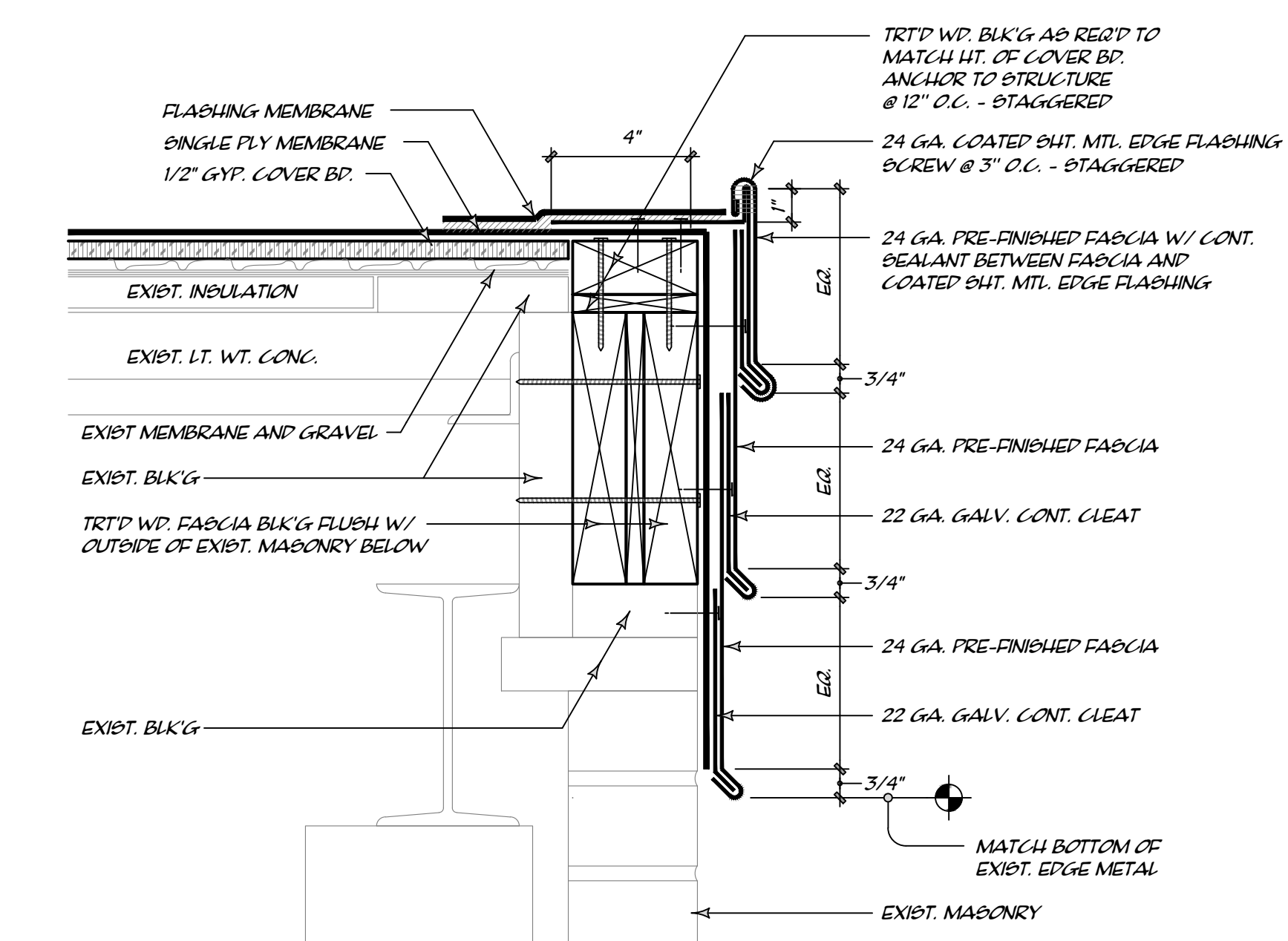

1 ROOF EDGE  
RS 3" x 1'-0"

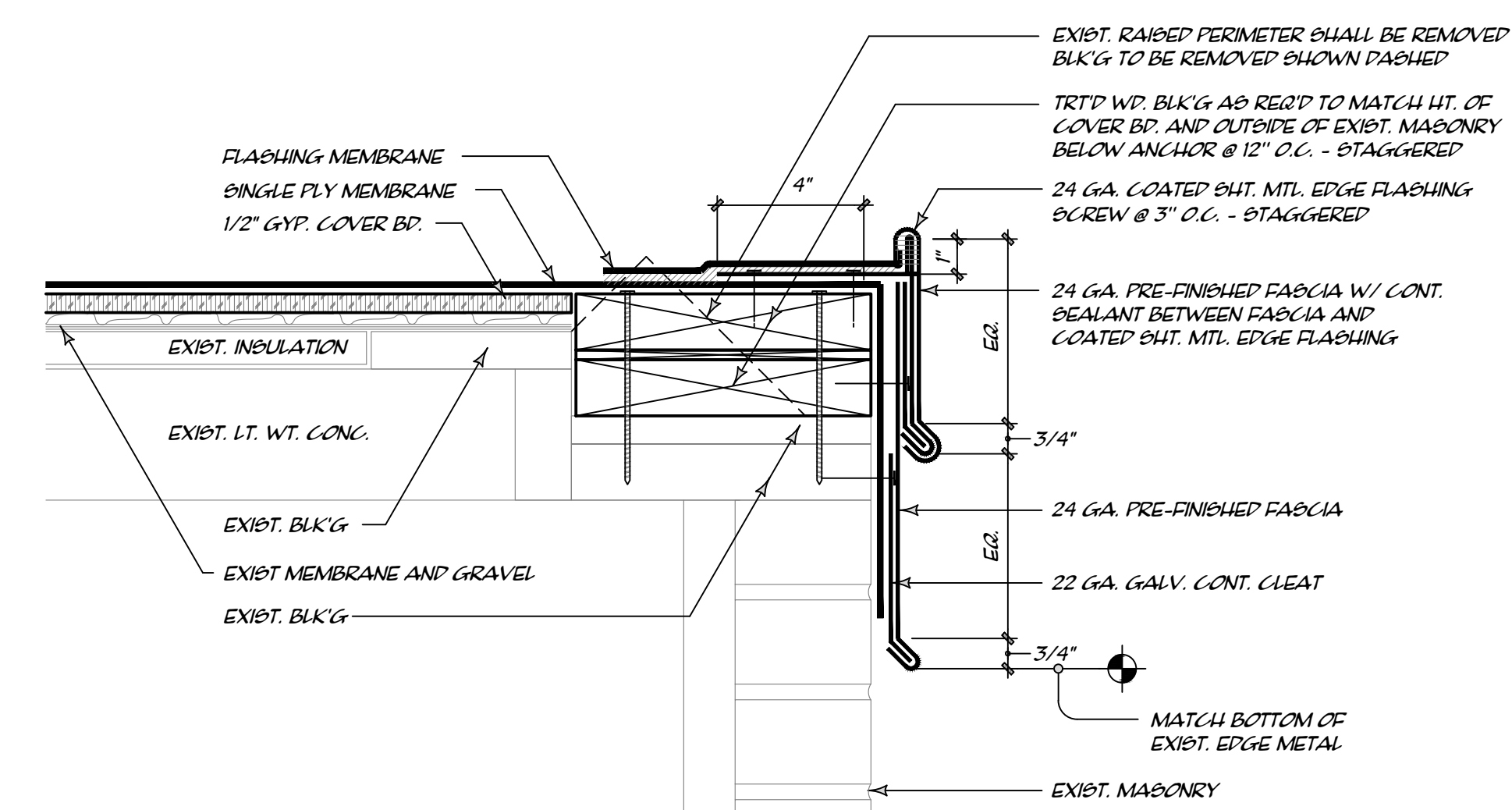

2 ROOF EDGE  
RS 3" x 1'-0"

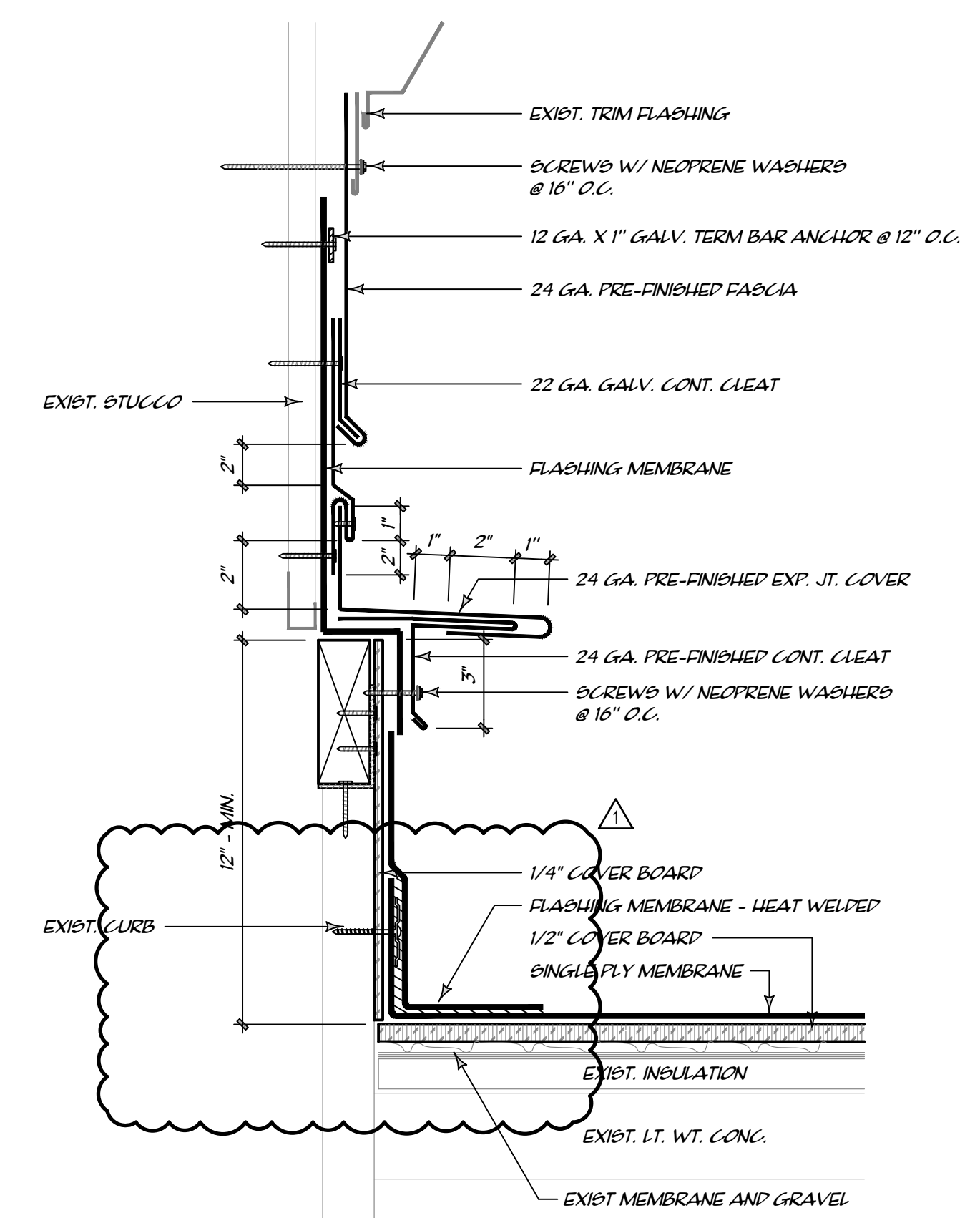

3 WALL FLASHING - SURFACE MOUNT  
RS 3" x 1'-0"

NOTE:  
1. ANCHOR RECEIVER IN SAW-CUT REGLET W/ LEAD WEDGES @ 12" O.C.  
2. PROVIDE CLOSED CELL BACKER ROD BETWEEN LEAD WEDGES  
3. EXTEND REGLET AND COUNTERFLASHING 4" BEYOND JAMB FLASHINGS

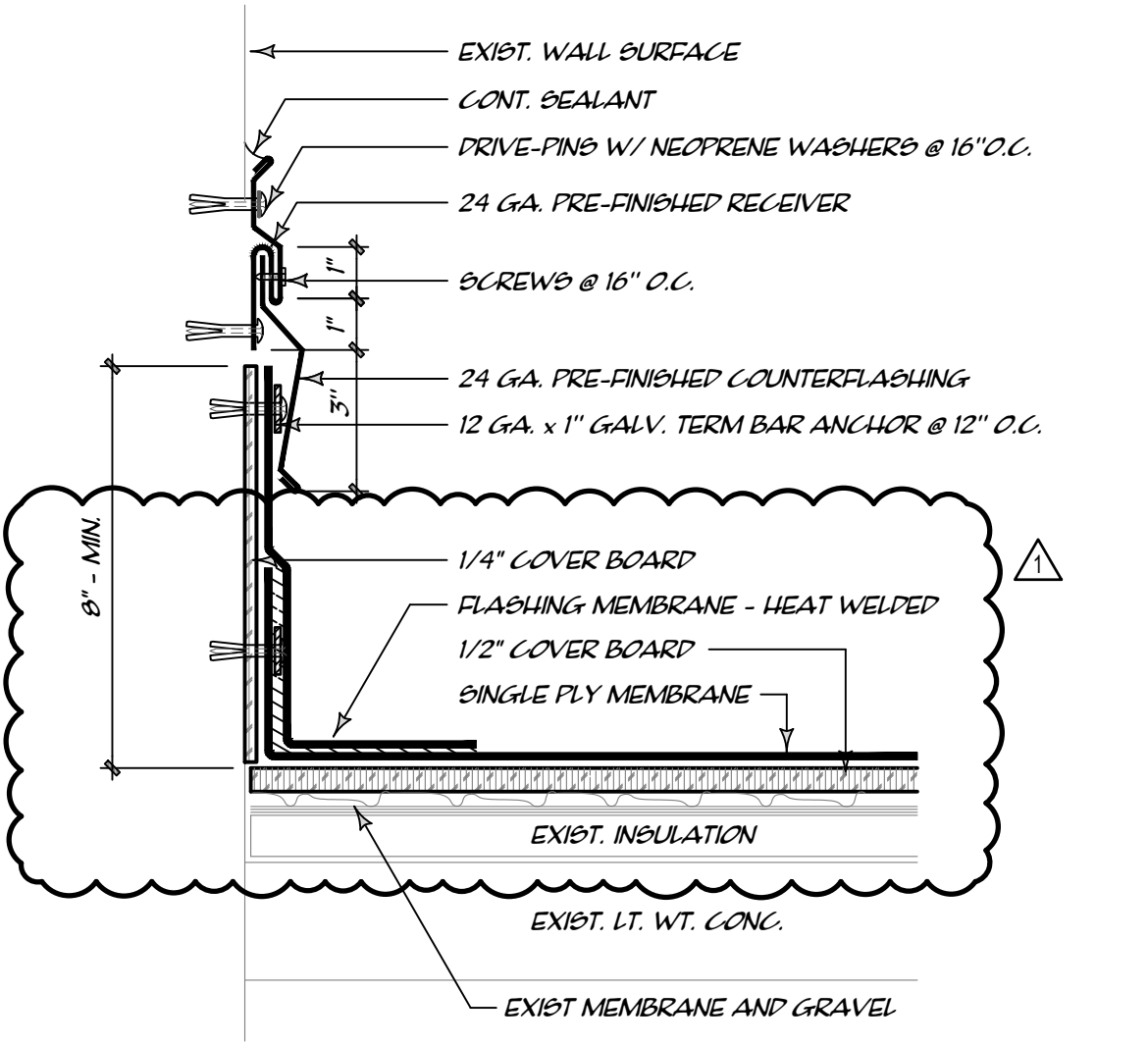

4 WALL FLASHING - SURFACE MOUNT  
RS 3" x 1'-0"

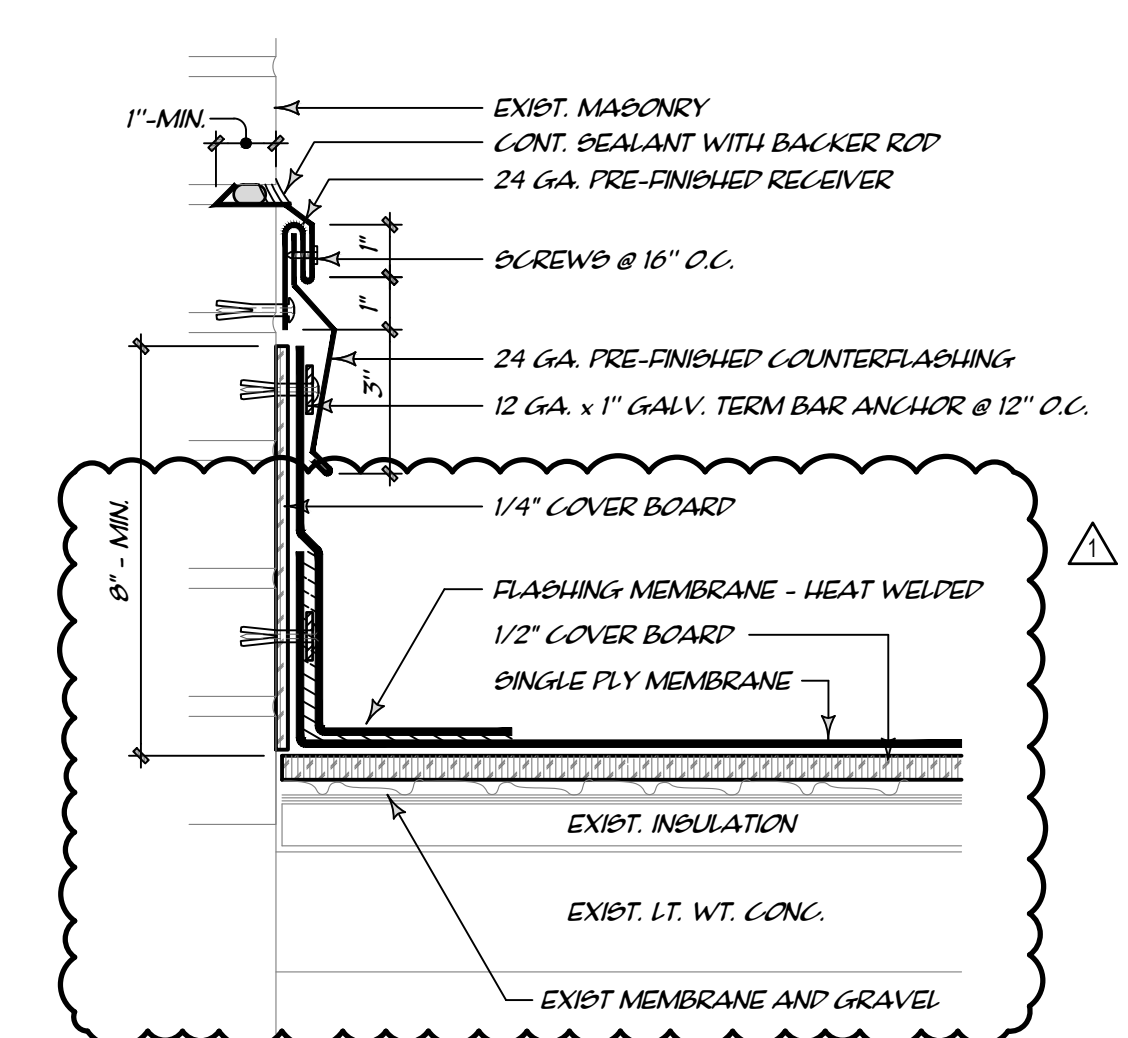

5 WALL FLASHING - REGLET  
RS 3" x 1'-0"

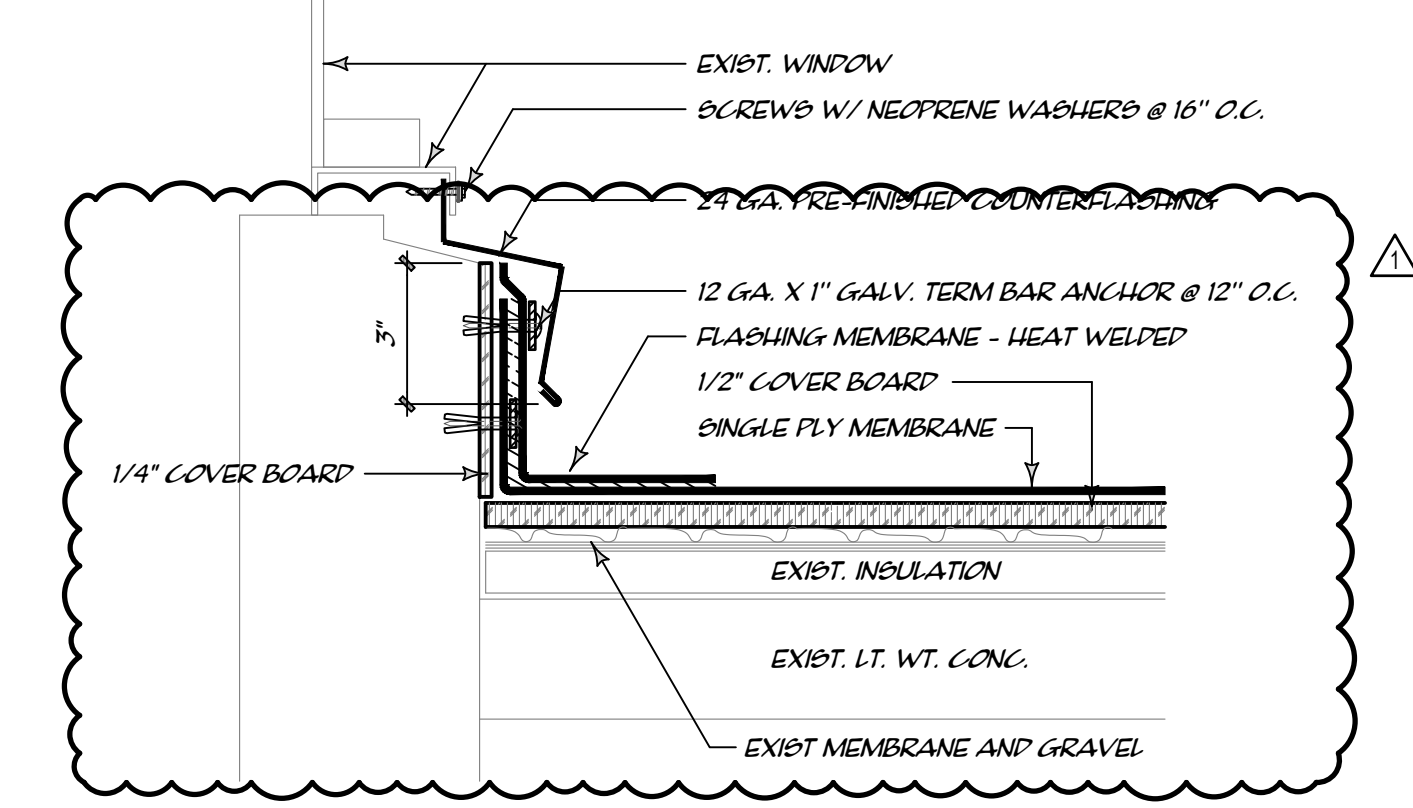

6 WINDOW FLASHING  
RS 3" x 1'-0"

NOTE:  
1. ANCHOR RECEIVER IN SAW-CUT REGLET W/ LEAD WEDGES @ 12" O.C.  
2. PROVIDE CLOSED CELL BACKER ROD BETWEEN LEAD WEDGES  
3. EXTEND REGLET AND COUNTERFLASHING 4" BEYOND JAMB FLASHINGS

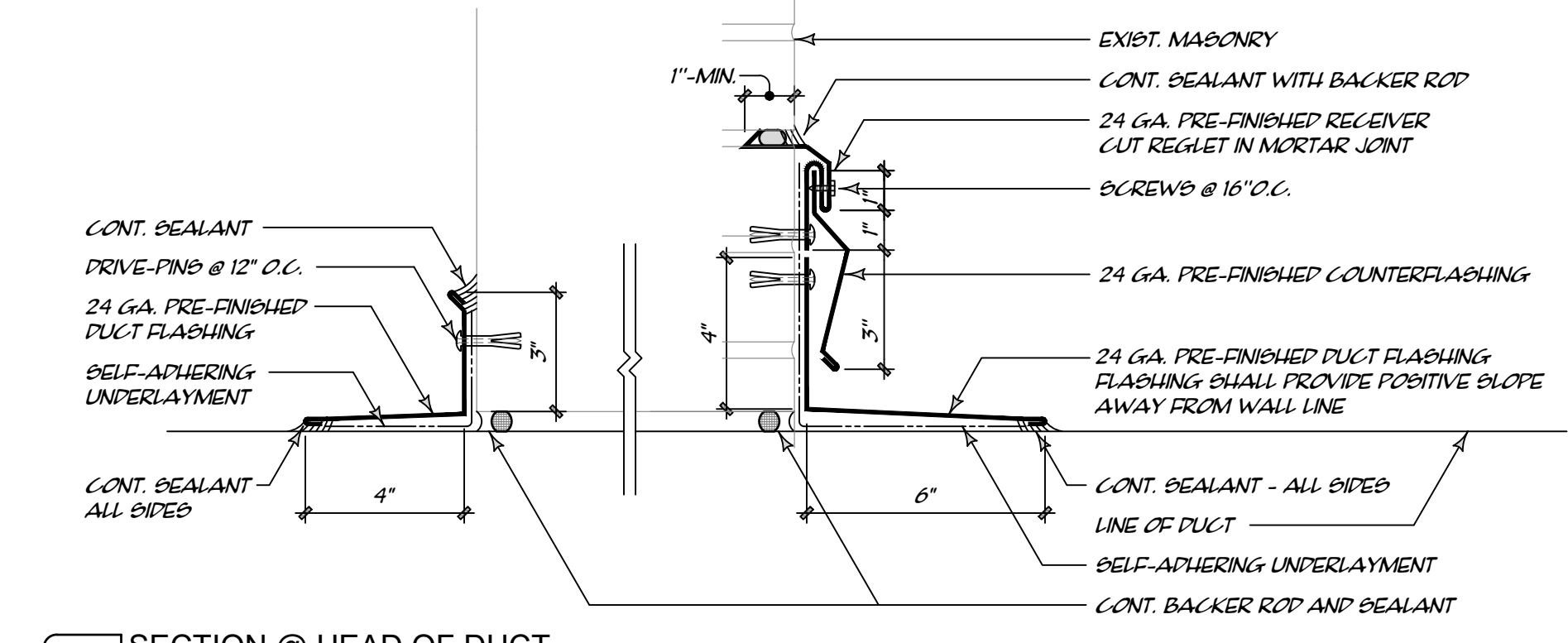

A SECTION @ HEAD OF DUCT  
NOT TO SCALE

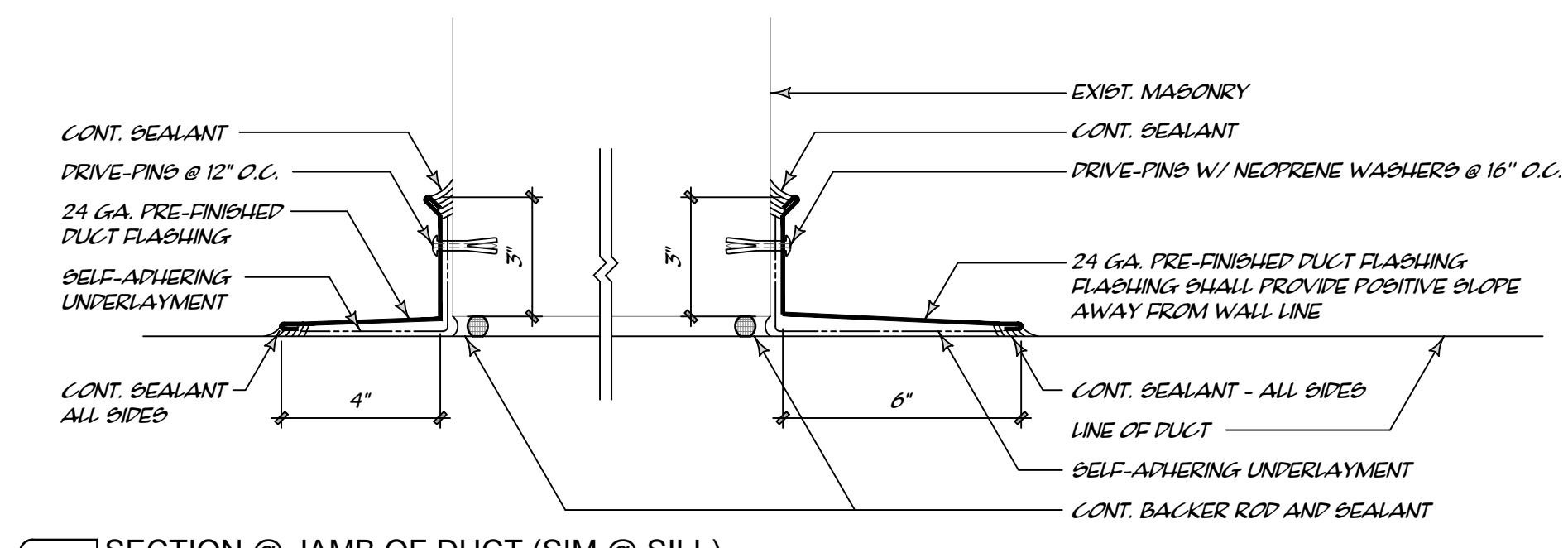

B SECTION @ JAMB OF DUCT (SIM @ SILL)  
NOT TO SCALE

7 DUCT PENETRATION FLASHING  
RS 3" x 1'-0"

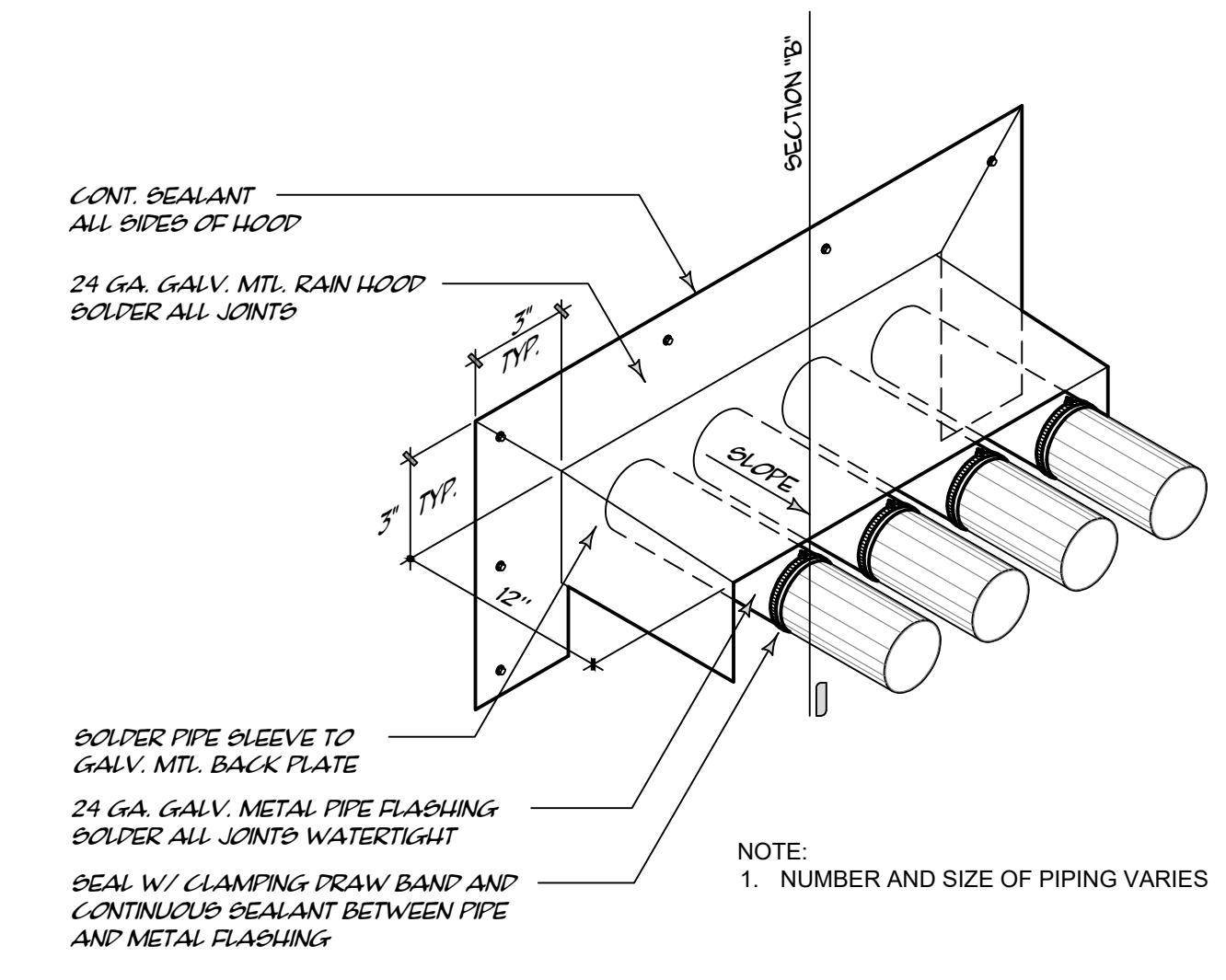

A ISOMETRIC  
NOT TO SCALE

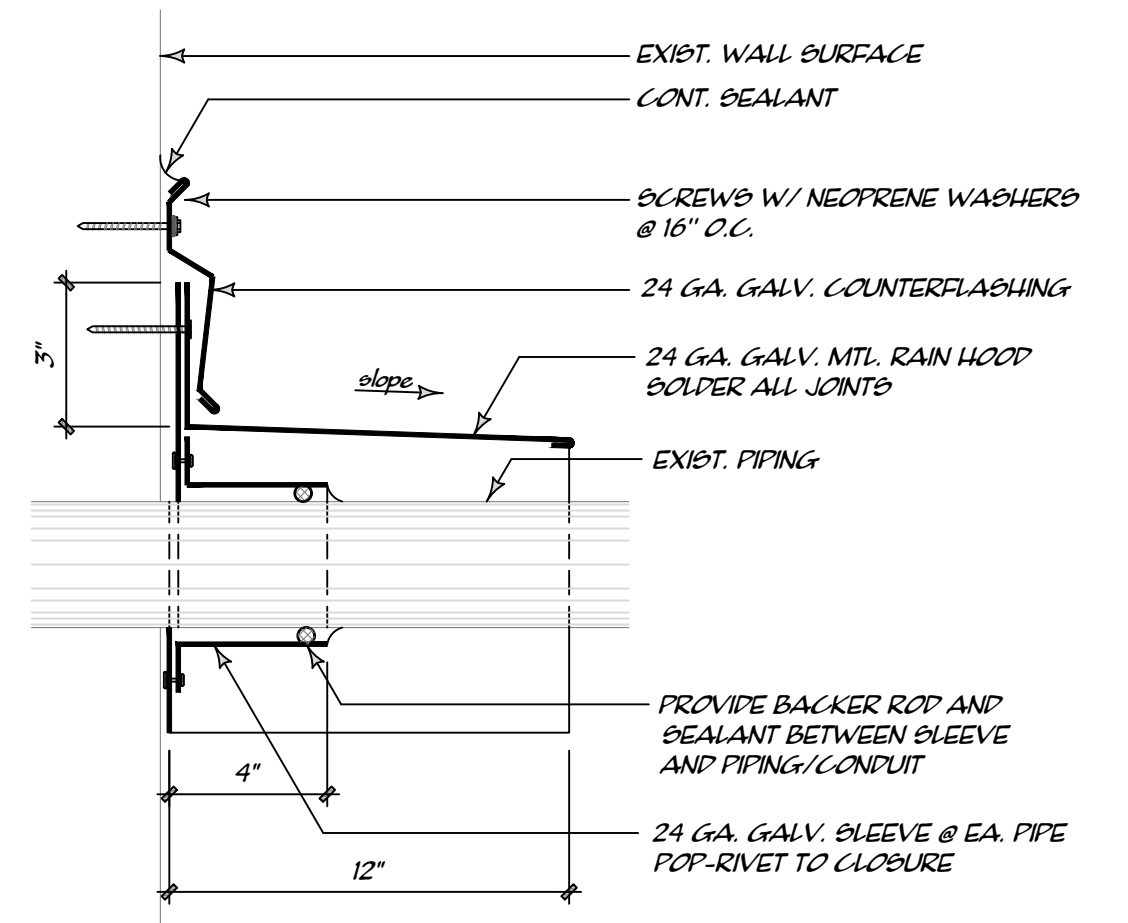

B SECTION  
3" x 1'-0"

8 PIPE FLASHING  
RS 3" x 1'-0"

AUSTIN  
INDEPENDENT SCHOOL DISTRICT  
ROOFING REPAIRS AT  
MARTIN MIDDLE SCHOOL  
PROJECT NO.: 19-0037-MARTN  
SOLICITATION NO.: 21CSP034

REVISION SCHEDULE:	
1.	ISSUE FOR BID 10/11/20
2.	ADD #2 10/22/20
3.	
4.	
5.	
6.	
7.	



ROOFING DETAILS	
DRAWN BY:	MWH
CHECKED BY:	RR
DATE:	10/11/2020
SHEET:	R5 OF 5